

# **JINMA SERIES TRACTOR OPERATION MANUAL**

**JINMA-200**

**JINMA-204**

**JINMA-250**

**JINMA-254**

**JINMA-300A**

**JINMA-304A**

**MAHINDRA YUEDA  
(YANCHENG) TRACTOR CO.,LTD.**

# Preface

Jinma series wheeled tractors (JM-200、JM-204、JM-250、JM-254、M-300A、JM-304A) are small four wheel tractors of new type , which are developed according to the increasingly rising demands of domestic and overseas agricultural machinery for small new wheeled tractors . The tractors have the characteristics of saving energy , high efficiency , varied purpose ,beautiful appearance . If you buy them , you will get satisfactory economic profit from them .

Jinma series wheeled tractors respectively adopt vertical and energy saving diesel engine of 20, 25 , 30Hp as their power ;they employ direct gears transmission between engine and transmission system . Jinma tractors have many types for you to choose . They not only have single stage clutch and dual stage clutch types , but also have two wheel and four wheel drive types .They also have creeper device for you to choose if you want your tractors to conduct ditching operation . They have perfect hydraulic suspension system in performance , wide thread driving tyres of good adhesive force and low pressure and reliable (crankpin type and circulating ball type) but also have hydraulic steering gear , the users can choose either of them . The products are featured by their favourable power ,relatively high traction force , compact construction , high transmission efficiency ,easy operation , convenient repair and maintenance ,economical oil consumption ,easy attachment of implements and good comprehensive usage .

In order to help the customers master the Jinma series tractors' operation , adjustment and maintenance , and prolong their service life , make the best possible use of them and obtain ideal economic profit ,we compile the operation manual ,With regard to the operation and repair and maintenance , Please consult the operation manuals of the diesel engines .

With the development of science and technology and varying in requirement of customers , the tractors are subject to improvements and perfection in their constructions which will be written about in next editions of the manual . Therefore , users of tractors are required to pay attention to where the manual differs from the actual tractors .

## Precautions

1. Drivers should read the operation manual carefully and be familiar with the performance, operation and maintenance of the tractor. Otherwise we will not be responsible for any quality problems caused by improper operation.

2. Never fill the fuel tank with unfiltered or un-precipitated fuel.

3. New tractors must undergo running according to the regulations before they are put into use.

4. It is prohibited to turn sharply with one-side braking while tractor runs at high speed in order to avoid overturning or parts damage.

5. Bolts or nuts of wheel disc and of other important parts should be checked regularly and be tightened if they are loose.

6. During transferring the tractor with a mounted implement, it is not allowed to drive the tractor at high speed in order to avoid damaging hydraulic lift system and suspension system.

7. After operation at the area of below 0 °C in winter, the water should be drained out at idle speed in order not to freeze and damage the tractor parts (not including anti-icing fluid).

# CONTENTS

Preface .....	(1)
Precautions .....	(2)
Chapter I Main Specifications .....	(1)
Chapter II Operating the Tractor .....	(5)
1.Fuel and lubricating oil .....	(5)
2.Water .....	(6)
3.Running-in of unused tractor .....	(6)
4.Controls and instruments .....	(8)
5.Control and operation of the tractor .....	(10)
6.Control and operation of the working devices .....	(14)
7.Use of the electrical equipment .....	(16)
Chapter III Technical Maintenance of the Tractor .....	(19)
1.Shift maintenance .....	(19)
2.First class maintenance .....	(19)
3.Second class maintenance .....	(20)
4.Third class maintenance .....	(20)
5.Fourth class maintenance .....	(20)
6.Maintenance in winter .....	(21)
7.Maintenance for storage of a long time .....	(21)
Chapter IV Adjustment of Tractor .....	(22)
1.Adjustment of clutch .....	(22)
2.Adjustment of main drive .....	(24)
3.Adjustment of differential lock .....	(27)
4.Adjustment of brake .....	(28)
5.Adjustment of front axle .....	(30)
6.Adjustment of front drive axle .....	(31)
7.Adjustment of wheel tread .....	(33)
8.Adjustment of steering gear .....	(34)
9.Construction and adjustment of hydraulic hitch system .....	(39)
10.Use and adjustment of air brake device of trailer .....	(46)
Chapter V Main Troubles of Tractors and Trouble Shooting .....	(49)
1.Engine .....	(49)
2.Transmission system .....	(51)

3.Brake .....	(52)
4.Steering gear and walking system .....	(53)
5.Hydraulic hitch system .....	(54)
6.Electrical system .....	(55)
7.Electrical system .....	(56)
<b>Chapter VI Appendix .....</b>	<b>(59)</b>
1.Wiring diagram of the electrical system .....	(59)
2.Accessaries for customers to order .....	(59)
3.Distribution diagram of rolling bearing and transmission system of JM series tractors .....	(61)
4.Specifications and distributions of oil seals in JM series tractor's chassis .....	(63)
5.Sizes of hitch system .....	(65)
6.OECD approval No. of JM series tractors .....	(67)

## Chapter I Main Specifications

Model		JM-200	JM-204	JM-250	JM-254	JM300A	JM304A
Type		4 × 2wheeled	4 × 4wheeled	4 × 2wheeled	4 × 4wheeled	4 × 2wheeled	4 × 4wheeled
Overall dimensions (mm)	Length	3080	3080	3080	3080	3200	3200
	Width(without ballast)	1250/1410	1250/1410	1280/1440	1280/1440	1280/1440	1280/1440
	Heiht(to steering wheel)	1910	1910	1930	1930	1930	1930
Wheel base (mm)		1465	1510/1560	1587.5	1588		
Wheel tread (mm)	Front wheel	1070 -1270	950 / 1050	1070 -1270	950 / 1050	1070 -1270	1050
	Rear wheel	1040-1200	1040-1200	1040-1200	1040-1200	1040-1200	1040-1200
Ground clearance (mm)		330	275	340	340		
Turning radius (m)	With one-side braking without braking	2.4 ± 0.2	2.8 ± 0.2	2.75 ± 0.2	2.8 ± 0.2	2.75 ± 0.2	2.8 ± 0.2
		2.8 ± 0.2	3.0 ± 0.2	3.0 ± 0.2	3.0 ± 0.2	3.0 ± 0.2	3.0 ± 0.2
Weight (kg)	Construcional weight	1040	1140	1040	1140	1170	1270
	Min.working weight	1160	1270	1060	1270	1290	1400
Rated traction force (N)		4000	4800	5200	5980	5200	5980
Normal speed (km/h)		six	six	six	six	eight	eight
Forward:	1 st	1.99 0.37	1.68 0.31	2.06 0.38	1.73 0.32	2.12	1.77
	2nd	3.94 0.73	3.31 0.62	4.07 0.76	3.42 0.64	3.24	2.69
	3rd	6.57 1.22	5.52 1.03	6.79 1.27	5.71 1.06	5.08	4.23
	4th	9.21 1.72	7.75 1.45	9.52 1.78	8.01 1.49	7.00	5.83
	5th	18.2 3.39	15.3 2.85	18.8 3.51	15.8 2.59	9.82	8.18
	6th	30.36 5.66	25.5 4.76	31.4 5.85	26.4 4.92	14.97	12.46
	7th					23.49	19.56
	8th					32.38	26.96
Reverse:	1st	1.58 0.29	1.33 0.29	1.63 0.30	1.37 0.26	2.79	2.32
	2nd	7.3 1.36	6.15 1.15	7.55 1.41	6.35 1.18	13.52	11.25
Engine	Model	LL380	LL380	KM385	KM385	ZN390T	ZN390T
	Type	3 cylinder ,vertical ,water - cooled , 4-stroke					

Model		JM-200	JM-204	JM-250	JM-254	JM300A	JM304A	
Engine	12-hour power(kW)/rated speed r.p.m	14.7	14.7	18.4	18.4	22.1	22.1	
	Bore × Stroke(mm)	80 × 90	80 × 90	85 × 90	85 × 90	90 × 95	90 × 95	
	Fuel consumption (g/kw·h)	≤ 245	≤ 245	≤ 245	≤ 245	≤ 255	≤ 255	
	Oil consumption (g/kw·h)	≤ 2.0	≤ 2.0	≤ 2.0	≤ 2.0	≤ 2.72	≤ 2.72	
	Net weight (kg)	250	250	250	250	230	230	
Transmission	Clutch	Single disc,dry-friction constant mesh OR Dual stage ,gear operation						
	Gear box	Supr gear (3 + 1) × 2 compound , or supr gear (4+1) × 2compound Creeper can b chosen						
	Intermediate drive	1 × 2 spiral bevel gear						
	Differential	Closed with 2 planetary bevel gears						
	Diffierential lock	Claw type						
	Final drive	Internally meshed single spur cylindrical gear						
Walk and operating system	Frame type	Frameless rigid connection						
	Front axle type	inverted U pipe balancing arm	side bevel gear drive	inverted U pipe balancing arm	side bevel gear drive	inverted U pipe balancing arm	side bevel gear drive	
	Pendulum angle of front axle	12 °	8 °	12 °	8 °	12 °	8 °	
	Tyres	Front wheel	4.00-16	6.00-12	5.00-15	6.00-16	5.00-15	6.00-16
		Rear wheel	8.3-24	8.3-24	9.5-24	9.5-24	9.5-24	9.5-24
	Tire infation pressure (kPa)	Front wheel:	200-250	180-200	200-250	180-200	200-250	180-200
		Rear wheel :	100-120	100-120	100-120	100-120	100-120	100-120
		(in field) (transportation)	120-140	120-140	120-140	120-140	120-140	120-140
Steering gear	sphere worm steering							
	Hydraulic steering gear may be chosen for all models							
Brake	Foot - controlled shoes type			Disc type				

Model		JM-200	JM-204	JM-250	JM-254	JM300A	JM304A
Hydraulic systems	Type	Half remote					
	Hydraulic pump	CBN-E306 gear pump	CBN-E306 / 314 gear pump	CBN-E306 gear pump	CBN-E306 / 314 gear pump	CBN-E310 gear pump	CBN-E310 gear pump
	Hydraulic cylinder	Horizontal single- acting type $\square 63 \times 100(\text{mm})$					
	Distributor	Slide valve regulating type					
	Safety valve	Direct-acting type					
	Rated lifting capacity (N $\times$ mm)	3600 $\times$ 610	3900 $\times$ 610	4200 $\times$ 610	4200 $\times$ 610	5000 $\times$ 610	5000 $\times$ 610
	Safety valve release pressure(MPa)	16 ( 0 $\sim$ + 1.6 )					
Suspension mechanism	Connection type of implements	rear mounted - point hitch category 0		rear mounted - point hitch category I			
	Upper link-hole diameter(mm)	$\phi 19.5 \times 44$					
	Lower link-hole diameter(mm)	$\phi 22.5 \times 35$					
Traction device	Traction ground clearance(mm)	470		495			
	Traction pin diameter(mm)	$\Phi 20$					
Power-take-off	Rear P.T.O shaft	Nonindepender 540r/min or semi-independent 540r/min, dual speed(540r/min ,1000r/min)can be chosen					
Electrical equipments and gauges	System	12V ,negative pole connected with iron , single phase circuit					
	Starter	12V、 2.5kW or 3.0kW					
	Generator	14V 350W					
	Battery	6-Q(A)-80,80A·h					



Model		JM-200	JM-204	JM-250	JM-254	JM300A	JM304A
Electrical equipments and gauges	Ammeter	-30~0~ + 30 (A)					
	Oil pressure gauge	12V (0~0.5) MPa					
	Water temperature gauge	12V (40~100) °C					
	pressure gauge	0~1.0 MPa					
	Head lamp	ND118-80T , 20/8W 12V					
	Rear light	WD115-2 , 20/8W.12V					
	Direction light	FT12 , 8W.12V					
	Electric horn	DL87-12					
Main filling capacity (L)	Fuel tank	19	19	19	19	24	24
	Engine oil sump	5					
	Front drive axle	—	4.5 / 6	—	6	—	6
	Transmission box	11	14	11	14	11	14
	Lifter	9				14	
	Steering gear	0.4					
	Cooling water	10 or 12					

## Chapter II Operating the Tractor

### 1. Fuel and lubricating oil

1) For fuel and lubricating oil for the tractor see Table 2-1.

Table 2-1 Fuel and lubricating oil for the tractor

Component	Season and ambient temperature	Oil specification
Fuel tank	Summer (ambient temp. above 10 °C )	No.0, -10 light diesel fuel GB252-87
	Winter (ambient temp. below 10 °C )	No. -20 light diesel fuel GB252-87
Engine sump	Ambient temp. below 0 °C	No. 20 diesel engine oil GB5323-85
Lifter	Ambient temp. at 0-25 °C	No. 30 diesel engine oil GB5323-85
Oil pan of air cleaner	Ambient temp. at 0-25 °C	No. 30 diesel engine oil GB5323-85
Injection pump	Ambient temp. above 25 °C	No. 40 diesel engine oil GB5323-85
Hydraulic steering gear	Ambient temp. above 25 °C	No. 40 diesel engine oil GB5323-85
Transmission box	Summer (ambient temp. above 10 °C )	No. 40 diesel engine oil GB5323-85
Transfer case Front drive axle Mechanical steering gear	Winter (ambient temp. below 10 °C )	No. 30 diesel engine oil GB5323-85
Grease nipple	Without consideration of season	No. ZFG2 calcium base compound grease ZBE 36003-88
Bearing 60203 Generator and starter	Without consideration of season	No. ZFG2 compound calcium base grease ZBE 36003-88

#### 2) Cautions for filling fuel

Using clear diesel fuel is an important factor to prevent troubles in engine and prolong the engine's service life. The followings should be observed during filling fuel:

- A. Fuel must be deposited for over 48 hours before fuel tank is filled with it. Fuel at the bottom should not be poured into the fuel tank.
- B. Filter fuel when filling fuel tank with it.
- C. Fuel filling devices must be kept clean.
- D. Fuel tank and fuel filter should be cleaned regularly, and deposited fuel should be drained out.

## **2. Water**

**1) Radiator should be filled with clean soft water so as to eliminate scale in the engine cooling**

**system which will reduce cooling efficiency. Only after being softened can hard water such as well water, spring water, etc. be used. Method for softening hard water is as the follows:**

**A. Boil hard water, then deposit for some time and filter.**

**B. Put 1.5g of caustic soda into one lit of hard water. When operating the tractor in cold weather, add cooling water with freeze-proof liquid.**

## **3. Running-in of unused tractor**

**The unused or overhauled tractor can not be put into operation unless it has undergone running-in. Otherwise its performance will be affected and service life will be shortened.**

**1) Preparations before running-in**

**A. Clean the outside of the engine.**

**B. Inspect outside bolts and nuts, and tighten them if necessary.**

**C. Check the lubricating oil level, and refill to stipulated level if insufficient.**

**D. Inject grease into lubricating points.**

**E. Fill with fuel and cooling water**

**F. Check toe-in (4-10mm) and tire inflation pressure, readjust or reinflate if necessary.**

**G. Inspect the connections of battery and wires of electrical system.**

**2) Idle running-in of the engine**

**After the engine is started in accordance with specified steps, listen carefully and make sure whether there is abnormal sound, check for leakage of water, air, oil and the readings of the gauges. When it is made sure that the engine is in normal working condition, the next step of running-in can be proceeded.**

**The unloaded running-in lasts 15 minutes, the first 7 minutes with minimum throttle, then medium throttle for other 5 minutes and then lasts 3 minutes with full throttle.**

**3) Unloaded and loaded running-in of the tractor**

**The running-in of the tractor should be done at rated engine speed. The order and time of running-in should be done according to the standard in Table 2-2.**

**Table 2-2 Running-in standard of the tractor**

Running-in type	Load	Running-in hours per gear								Total	Sum
		1st	2nd	3rd	4th	5th	6th	R1st	R2nd		
Unloaded	Tractor only	1	1	1	1	0.5	0.5	0.5	0.5	6	
Loaded	With trailer loaded with 1.2T goods on highway transportation	1	2	4	4	2	2			15	31
	Fitted with plough at plough depth about 13.3cm in light soil	1	2	4	3					10	

Matters needing attention during running-in process:

A. Check on whether the engine runs normally.

B. Check on whether the adjustment of the clutch is normal and the disengagement is complete.

C. Check on whether the gear shift of the gearbox (including front drive handle, creeper) is light and flexible, and there is any automatic gear disengagement and gear-shifting lock.

D. Check on the function or reliability of the brake.

E. Check on whether the steering gear is flexible.

F. Check on whether the gauges and electrical equipments are normal and reliable.

During the running-in process, if any abnormal phenomena or failures appear, the cause should be found out and corrected, then the running-in can be carried on.

After the running-in is completed, the tractor must be undergone the following maintenance before being put into operation:

A. After the tractor has been stopped, drain out the lubricating oil in the engine sump while it is still warm. Wash the sump and oil filter with diesel fuel. After the diesel fuel has been out, refill the sump with new lubricating oil to specified level.

B. Drain out the lubricating oil in the transmission box, hydraulic system and front drive axle while it is still warm. Then fill them with diesel fuel of proper quantity and run the tractor in 2nd forward and 1st reverse gears for 2-5 minutes for cleaning. As soon as the tractor is stopped, drain out the diesel fuel immediately and then refill new lubricating oil to specified level.

C. Clean fuel filter (including filter cartridge in fuel tank) and air cleaner.

D. Drain out cooling water, clean the cooling system of engine with clean water.

E. Check on and adjust the free travel of clutch pedal, the travel of brake pedal and the

working condition of the brake.

**F. Check on and tighten the nuts and bolts on all connection positions.**

**G. Check on injector and valve clearance, adjust them if necessary.**

**H. Check on working conditions of electrical system.**

**I. Check on and adjust the toe-in of front wheel.**

**J. Inject grease into each lubricating point.**

#### **4. Controls and instruments**

In order to operate the tractor correctly, it is necessary to familiarize the function of all controls and instruments as well as their positions on the tractor (Fig.2-1).

- 1) **Auxiliary gear shifting lever:** To control the auxiliary speed gear. (Fig.2-2).
- 2) **Main gear shifting lever:** To control the main speed gear. (Fig.2-2).
- 3) **Gear shifting pattern plate:** It is located on the top of gearbox cover to show the positions of gear shifting lever.
- 4) **Control lever of front drive axle:** Engage or cut off the power of front drive axle to achieve 4-wheel drive or 2-wheel drive.
- 5) **Steering wheel:** It controls the direction of tractor running.
- 6) **Clutch pedal:** Depress the pedal, then the clutch is disengaged.
- 7) **Decompressing lever:** Reduce the pressure in the cylinders to make the engine start easier.
- 8) **Extinguishing lever (Fuel cut-off rod):** To make the engine stop.
- 9) **Single-position switch:** Pull the switch out, the rear work light is turned on and push the switch in, it is turned off.
- 10) **Turning signal switch:** Turning the switch to the left or right, the left or right turning signal light will flash to show in the left or right turning.
- 11) **Horn button:** Press the button to sound the horn, and it will send out alarm signals.
- 12) **Ammeter:** It indicates the current intensity of battery while being charged or discharged. If the pointer deflects to "+" side, it means that the battery is being charged; if to "-" side, it is being discharged.
- 13) **Water temperature gauge:** Indicates the water temperature of the engine cooling system.
- 14) **Tachometer:** It indicates the speed and accumulated working time of the engine.  
**Air pressure meter:** It indicates the air pressure of the brake system (for 2WD).
- 15) **Oil pressure gauge:** It indicates the oil pressure in main oil lines of the engine, the normal oil pressure is 2-4 kgf/cm<sup>2</sup> (0.2-0.4MPa).
- 16) **Fuel gauge:** It indicates the fuel level of the fuel tank.

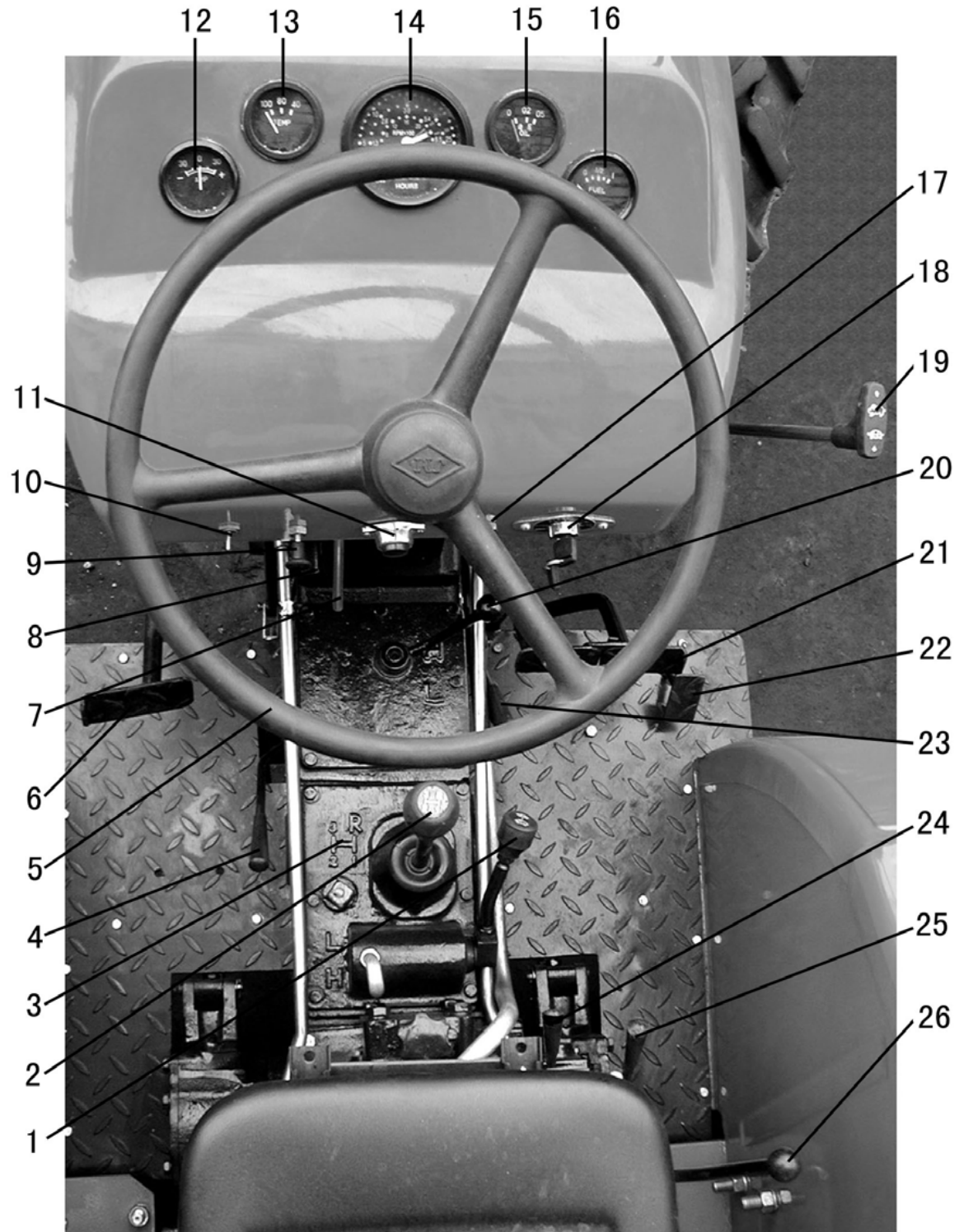

Fig.2-1 Controls and Instruments

17) Two-position switch: Pull the switch to the first position, the headlights (lower beam) will be lighted, to the second position, the full-beam of the headlights will be lightened.

18) Starting switch: It has two functions: one is for switching on or off the circuit current and the other is as electrical starting switch.

19) Hand throttle: Pull the hand throttle backward, the fuel flow will increase while push it forward, fuel flow will decrease.

20) Creeper shifting lever: To exchange the normal speed and creeper speed.

21) Left and right brake pedals: Turn the braking lock plate right to make left and right pedals connect with each other and brake at the same time; while separating the braking lock plate can achieve left or right one-side brake, then one-side brake and turn can be made.

22) Foot throttle pedal: Depress the pedal down, the fuel flow will increase; loosen it, the fuel flow will decrease.

23) Parking brake lock pawl: Put the brake lock pawl on the left brake pedal into the teeth of the brake teeth plate at the right side of transmission box to keep the brake for a long period.

24) P.T.O control lever: Engage or disengage P.T.O power.

25) Differential lock lever: Used to move right claw to make differential lock disengaged or engaged so that the two driving wheels have different speeds or not.

26) Hydraulic control lever: When the lever is pushed or pulled backward, forward or into vertical position respectively, the hitch is lifted, lowered or in neutral position.

## **5. Control and operation of the tractor**

### **1) Starting engine**

Before starting the engine, check fuel, lubricating oil and cooling water. Check and make sure every component and electrical system work correctly, drain out the air in the fuel lines, put gear shifting lever in neutral position. If the hydraulic system is installed on the tractor, caution: check whether enough hydraulic oil is filled in the lifter housing.

After the prestarting preparation, start the engine.

A. Set to decompress and rotate the engine crankshaft several turns with the hand starting handle, check and make sure all moving parts work correctly, and pump oil to surfaces of moving parts.

B. When starting the engine with the hand starting handle, set the hand throttle to full open position, put the decompression lever to the decompression position, accelerate the cranking, the engine will be started along with the decompression lever return automatically to original position.

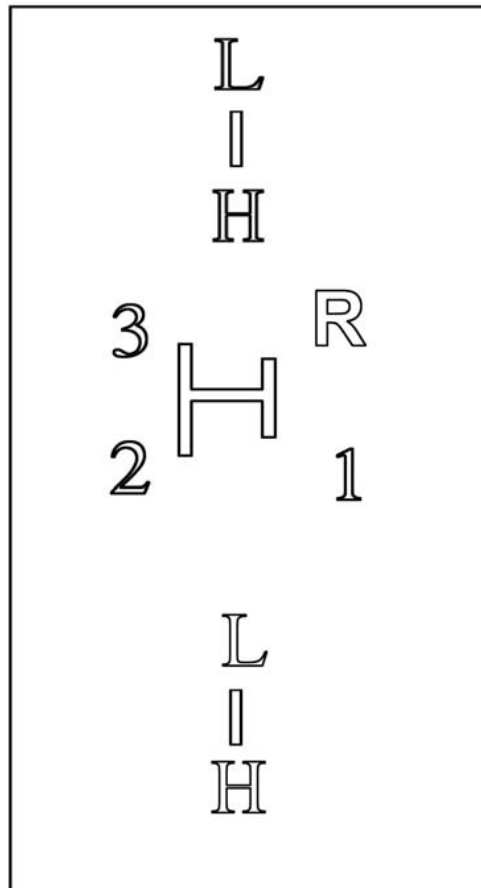

Fig.2-2 Diagram of shifting lever position

**C. When switch starting, set the decompression lever to decompression position too. Turn the starting switch clockwise to "start" position, thus the engine is driven by starter, the starter must not be operated more than 5-10 sec. for each start. Only after an interval of not less than 2 minutes can the engine be started again.**

**D. When switch starting is successful, turn the starting switch counterclockwise to the charging position of battery.**

**E. It is not necessary to decompress the engine while switch starting in summer. Filling the radiator with hot water or the oil sump with heated engine oil can be used as starting aids in winter.**

## **2) Starting the tractor**

**After the engine is started, run it at moderate speed for 5-10 minutes for warm-up itself, after the water temperature reaches above 70 °C , tractor can be started according to following steps:**



**A.Lift the implement.**

**B.Depress the clutch pedal, put the gear shifting lever into the desired lower gear, release the parking brake lock pawl of the brake pedal.**

**C.Observe the environment to confirm that there are no obstructions on the road and sound the horn to call attention to the people.**

**D. Increase the engine speed gradually and simultaneously release clutch pedal so as to make the tractor start off smoothly.**

### **3) Operating the tractor**

**A.During operation make sure that readings on gauges are normal.**

**B.It is prohibited for operator to place his foot on clutch pedal so as to protect clutch from being damaged because of semi-engaged condition of clutch.**

**C. In transportation or running on highway, lock the left and the right brake pedals together with brake lock plate.**

**D. In field operation, one-side braking can be used to reduce turning radius, but it is prohibited to use one-side braking for sharp turning when the tractor is running at high speed or is used for transportation on highway, so as to prevent overturning and protect components from being damaged.**

**E. Proper speed should be selected to get best productivity. Table 2-3 shows the speeds for various operations.**

**Table 2-3 Speeds for different operations**

<b>Operation</b>	<b>Gear</b>
<b>Creeper</b>	<b>Ditching</b>
<b>L1st</b>	<b>Rotary cultivation</b>
<b>L2nd</b>	<b>Rotary cultivation, transportation</b>
<b>L3rd</b>	<b>Ploughing, harrowing, drilling</b>
<b>H1st</b>	<b>Ploughing, harrowing, drilling</b>
<b>H2nd</b>	<b>Transportation</b>
<b>H3rd</b>	<b>Transportation</b>
<b>R1st</b>	<b>To attach implements</b>
<b>R2nd</b>	<b>To attach implements</b>

#### **4) Stopping the tractor**

- A. Throttle the engine down to lower the speed of the tractor.**
- B. Depress the clutch pedal quickly and shift the gear-shifting lever to neutral position.**
- C. Release the clutch pedal and let engine run idle.**
- D. Depress the brake pedals to stop the tractor, then lock the pedals with the lock pawl.**

**Note:** In case the tractor has to be stopped suddenly, clutch pedals and brake pedals should be depressed simultaneously. It is prohibited to depress the brake pedals only, which will damage the parts.

**E.** If the tractor is to be parked for quite a while, the engine should be stopped. After the engine has been unloaded, it should run at low speed for some time until the cooling water temperature drops to 70 °C or lower, then pull out fuel cut-off rod to bring the engine to a stop.

**Note:** It is prohibited to stop the engine at once when its temperature is very high, or to stop the engine with decompression mechanism.

**F.** Turn the preheating/starting switch to "O" and pull out the key. If the tractor is going to be stored, turn off the fuel tank cock.

**G.** If the tractor is stopped when the ambient temperature is below 0 °C, screw off the radiator cap and turn on the water-drain cock on the bottom of the radiator and on the cylinder block to drain out water at idle engine speed so as to protect the body and radiator from being frozen (not including adding anti-icing fluid).

#### **5) Safety regulations for operation**

Safety regulations are very important for protecting drivers and tractors from hazard. They should be observed strictly in operation.

**A.** Inspect carefully the working condition of the engine and main components, and listen to whether there is abnormal sound or noise. Especially observe the technical state of clutch and brake. Check and tighten the bolts and nuts on main components of the tractor.

**B.** Make sure that there is no people or obstacle around the tractor and press horn button before starting off the tractor.

**C.** Don't go up and down the tractor during running. Never make check or repair under the tractor while the engine is still running.

**D.** Before the tractor goes up or down a slope, proper speed should be selected and don't coast, turn sharply or shift gears while driving down a slope.

**E.** In transportation, left and right brake pedals must be locked together. One-side braking can not be used for sharp turning when the tractor is running at high speed or with full load.

F. If front end of the tractor rises up in operation, throttle down the engine, disengage the clutch and reduce the load to protect the tractor from longitudinal overturning.

G. If the engine runs away, immediately pull out the fuel cut-off rod, move decompression lever to "decompressing" position or plug up fresh air into the engine instead of disengage clutch.

H. Lightening equipment must work well during operation at night.

I. Control lever should be placed in the neutral position when the four-wheel drive tractor is running idle or being used for transportation.

## **6. Control and operation of the working devices**

### **1) Control and operation of PTO**

PTO can be engaged and disengaged by means of operating the PTO control lever on the right side of the transmission box.

The speed of PTO is 540 rpm or 540 rpm and 1000rpm. When push down (from front and upper side) the control lever, PTO is engaged; while pull upper the control lever, PTO is disengaged. The operation steps are as follows:

A. Remove the PTO safety shield and drawbar, couple the desired driven machine to the PTO shaft.

B. Put the gear shifting lever at the neutral position.

C. Depress the clutch pedal fully, then shift the PTO control lever to the "engaged" position.

D. Release the clutch pedal slowly and the driven machine will run. First let the driven machine run at slightly open throttle for a while to ensure that nothing is wrong with the driven machine. Then make the throttle wide open and put the driven machine into operation.

Note: When the tractor with implement travels for a long distance, should shift the control lever to neutral position to cut off the power so as to avoid damaging the implement and causing body accident.

### **2) Control and operation of hydraulic hitch system**

Hydraulic hitch system serves to attach, lift and lower implement, as well as adjust and maintain the working position of implement, so as to meet different requirements of various implements and operations.

Move the control lever of the distributor to raise and lower the implement.

According to the type of work to be done, type of implement used and field condition, hydraulic hitch system provides various functions, so that the satisfactory work quality is obtained.

A. Position control

In position control, by means of moving control lever of the distributor, the position of

implement could be adjusted, if desired position of the implement has been got, set the position of the stopper on the return rod to limit the control lever. Tighten the stopper on the rod with screw, so that the lever can be pushed to the same position every time.

Adjustment may be done during plowing period. The supporting wheel for the implement is not necessary in position control.

#### **B.Floating control**

Floating control is suitable for field plowing. In floating control, supporting wheel is needed for implement, During plowing , hold the control lever of distributor at "lowering position. (i.e. push the control lever of distributor forward with the return stopper. Do not return the control lever to the neutral position). The hydraulic circuit is in "floating" control. Using floating control, the plowing depth is controlled by the change of the height of the supporting wheel. The uniform plowing depth would be obtained in the field with wild changes of soil resistance.

#### **C.Control of the lowering speed of the implement**

Turn the lowering speed adjusting valve to control the lowering speed of the implement. The lowering speed should be selected properly according to the weight of the implement and hardness of soil surface in order to prevent the implement from being seriously impacted and damaged.

Turn the lowering speed adjusting valve clockwise, the lowering speed will reduce; turn the valve counterclockwise, the lowering speed will increase.

#### **D.Operation of hitch system**

Adjust the implement according to the implement operation manual before the implements being attached to the hitch system of the tractors.

In ploughing, adjust longitudinal and lateral level of plough in order to get the same ploughing depth of front and rear share.

##### **a) Adjusting of longitudinal level**

Adjust the length of the upper link of the hitch, keep the plow frame horizontal in longitudinal level, so as to keep each share in the same plowing depth. As the front share plows deeper than the rear one, or heel of plow goes out from bottom of furrow, extend the upper link; as the front share plows shallower than the rear one, or rear heel sinks into the bottom of furrow, shorten the upper link.

##### **b) Adjusting of lateral level**

Adjust length of right lifting rod, keep plow frame horizontal in lateral level, as extend the right lifting rod, the plowing depth of the first share is increased. As shorten the right lifting rod, the ploughing depth of the first share is decreased. Usually, the left lifting rod does not

require any adjustment. Only if the right lifting rod is adjusted to its limits, the left lifting rod would be adjusted to obtain the uniform plowing depth.

In order to obtain better plowing quality in actual operation, still need to adjust the plowing width according to the plow operation manual, so that the twifallow and omitted plowing won't happen. The various adjustments described above are connected. According to each operation condition, combine the adjustments properly, then can obtain the best results.

The check chains can make the integral unit have good manoeuvrability in the field, and prevent implement from hitting rear wheels because of the too much crosswise swinging of the implement during turning of tractor and lifting the implement in the field ends. As the implement is in plowing position, the check chains are loosen, a certain swinging scope between tractor and implement is allowed. Adjusting the deviation traction of the implement through tensioning the check chains is prohibited during ploughing.

c) While using implements of driving type, should pay attention to the length of universal joint shaft; after attachment, there should be about 10mm axial clearance between PTO shaft and universal shaft.

### **3) Using the differential lock:**

In tractor transportation and operation, if one drive wheel slips greatly and the tractor can not move forward, operate the differential lock according to the following steps:

A. Depress the clutch pedal, move the gear shifting lever to the low range gear position.

B. Turn the hand throttle to full open position.

C. Depress down the differential lock lever under the right side of the seat, gradually release the clutch pedal to engage the clutch, so that two drive wheels rotate in same speed, then there is a possibility to drive the tractor through the slippery area.

D. After the tractor passes through the slippery area, can not turn the tractor, otherwise the parts may be damaged.

**Note:** Release differential lock lever and let it return to the original position after the differential lock is engaged.

## **7. Use of the electrical equipment**

The electrical equipment of the tractor is used to start engine, meet the needs of giving signals and lighting for operation at night and etc. The electrical system of the tractor is negative pole connected with iron, 12V single phase circuit.

### **1) Battery**

Battery rated voltage is 12V and its rated capacity is 60 or 66 AH; The battery is used to

store the spare electricity produced by the generator. While the engine doesn't work or run at low speed, the stored electrical energy can supply electricity for all of the electrical devices and to start the tractor. While the engine overloads in a short time, the battery can help to supply electricity. In routine use, the battery should be often checked and maintained in accordance with the technical maintenance regulations of the tractor.

A. Before using the new battery, fill the electrolyte stipulated in table 2-4 to the required height, then keep the battery for 15 minutes, after that, the battery can be used; after starting the engine, firstly it is better to charge the battery for 1-2 hours, which is good to extend the service life of the battery.

B. Dust and dirt on the outside of the battery should be often cleared away in case electricity leaks. Check to see whether the battery has crackle and electrolyte leak; keep the terminals and all contacts in good connecting condition; keep the air hole on the plastic cover unblocked, so as to protect the battery from explosion because of too much gas in the battery.

C. Check the height of electrolyte level and specific gravity. In normal use, if the height of electrolyte level is below 10-15mm, distilled water should be poured into it in time. Well water or river water can't be used. So as to prevent impurity from entering electrolyte. If electrolyte overflows much under unusual conditions, it can be added. The density of electrolyte in electrolytic cell should be not lower than 1.2g/cm<sup>3</sup>; if the density is too low, the battery should be charged in time.

D. The time of continuous starting should not be more than 10 seconds in case overdischarge. The battery should be charged at regular interval. The single voltage of the charged battery should be 2-2.1 V.

**Table2-4 Density of electrolyte**

Temperature of electrolyte(0 °C )	0-5	5-10	10-15	15-20	20-25	25-30	30-35	35-40	40-45
Density(g/cm <sup>3</sup> )	1.305	1.300	1.295	1.290	1.285	1.280	1.275	1.270	1.265

## 2) Use of generator and regulator

A. Generator should be used with regulator.

B. The generator is connected with ground by negative pole. The generator is connected with the regulator and the battery by negative pole. The positive and negative poles of generator, relay and battery can not be connected in wrong way. Otherwise the generator and regulator may be damaged.

C. Checking the generator by short circuit is prohibited. Megaohmmeter or A.C. power

of more than 100V is not allowed to check generator insulation; only multimeter of high resistance can be used to check the nature of generator insulation; otherwise the diode will be punctured.

### **3) The starter**

**A. Keep the starter clean and the contacts between wires in good condition.**

**B. The time for each starting should not be over 10 seconds. The shortest interval between two startings must be more than 2 minutes. If the engine can not be started after several startings, the trouble should be found out and removed, then the engine can be restarted.**

**C. If the engine is started in winter, it should be preheated and then can be started with the starter.**

## Chapter III Technical Maintenance of the Tractor

In order to keep the tractor in excellent condition, prolong its service life and reduce troubles, the users must often check the technical conditions of the tractor and strictly carry out technical maintenance of all classes.

**Table 3-1 Technical Maintenance Periodic Table**

Maintenance class	Working hours of the tractor (h)
Shift maintenance	After every shift or every 10-12 hours of operation
First class maintenance	Every 50 hours of operation
Second class maintenance	Every 250 hours of operation
Third class maintenance	Every 500 hours of operation
Fourth class maintenance	Every 1000 hours of operation

In actual use, users can add and perfect the contents and methods of maintenance according to concrete conditions.

### 1. Shift maintenance

1) Clean dirt and sludge on the tractor and implements. Under the extremely dusty circumstances, the air filter should be cleaned.

2) Check all main fastening bolts and nuts on the tractor outside, especially whether front and rear wheel nuts are loose, tighten if necessary.

3) Examine the liquid level in oil sump, radiator, fuel tank and lifter; refill if necessary. Only after the engine has stopped for more than 15 minutes can the oil lever in oil sump be examined.

4) Check whether there is leakage of oil, water and air; remove if necessary.

5) Check the tire pressure, and inflate if necessary.

6) Grease the points according to the table 2-1. Before greasing, the sludge and water should be squeezed from the lubricating points.

7) Check the specified tools supplied.

### 2. First class maintenance

Carry out the following maintenance after every 50 hours of operation:

1) Carry out the maintenance items in shift maintenance.

2) Clean air filter, and replace oil in the filter house.

3) Check the fan belt tension (When pressing the middle part of the longer side of the belt, the belt drops about 15-25 mm under the force of about 10N, then the tension is suitable), adjust if necessary.

4) Check and adjust the free travels of clutch pedal and brake pedals.



- 5) Check the oil level in transmission box and front drive axle, refill if necessary.
- 6) Wipe the battery with a piece of cloth, check the electrolyte level which should be 10-15 mm above the polar plates, refill with distilled if necessary . Smear the terminals with grease to avoid corrosion.

### **3. Second class maintenance**

Carry out the following maintenance after every 250 hours of operation;

- 1) Complete first class maintenance items.
- 2) Replace the engine oil in engine sump, flush engine sump, oil pump strainer and oil filter.

### **4. Third class maintenance**

Carry out the following maintenance after every 500 hours of operation.

- 1) Complete second class maintenance items.
- 2) Check and adjust inlet and exhaust valve clearance, injection pressure and spray atomization of the injector according to the requirements in the engine operation manual.
- 3) Clean fuel tank and fuel cartridge.
- 4) Flush transmission box, replace lubricating oil.
- 5) Flush the filter of hydraulic lifter, check the oil cleanliness degree, flush the inside of lifter house and replace with fresh oil if necessary.
- 6) Check and adjust front wheel toe- in (The toe - in should be 4-10 mm). Check the clearance of the front wheel bearing, and adjust if necessary. Replace the grease in the front wheel hubs.
- 7) Check the free travel of the steering wheel (The free angle should be less than  $15^{\circ}$  ), adjust if necessary.
- 8) Check the oil level in steering gear, and refill if necessary.

### **5. Fourth class maintenance**

Carry out the following maintenance after every 1000 hours of operation;

- 1) Complete third class maintenance.
- 2) Carry out maintenance items according to regulations in diesel engine operation manual.
- 3) Clean the fuel tank with 25% hydrochloric acid solution, then flush it with clean water.
- 4) Disassemble the starter and generator, clean off the grease in the bearings and replace it with fresh grease. Meanwhile examine the transmission mechanism of the starter.
- 5) Clean the gathered carbon in the silencer and exhaust manifold.
- 6) Immerse the front bearing and release bearing of the clutch into dissolved high temperature- resistant grease, and refill with fresh grease.

7) Check and adjust the meshing backlash and print of the main drive bevel gears, the bearing clearance and preload of the bevel gears.

8) Clean the oil filter in the hydraulic lifting system, replace the oil in the system with fresh oil.

9) Clean steering gear, replace the lubricating oil in it.

10) After the maintenance has been done, run the maintained tractor for a short time for trial to see whether every part is in normal condition.

## **6. Maintenance in winter**

While the tractor is used below 5 °C , the users should carry out special maintenance on the tractor. Besides completing the every shift maintenance, the following regulations should also be obeyed.

1) The engine is not allowed to be started if there is no water in the cooling system. Hot water of 60-80 °C can be poured into the radiator for easy starting the engine.

2) After cold starting, the engine should be preheated for a period of time; operation can not be conducted until the water temperature is above 60 °C .

3) If the tractor will stop for a long time after operation, the water (without anti- icing fluid in it ) in the cooling system should be drained out. Water temperature of draining out is 50-55 °C .

4) Choose fuel and lubricating oil according to air temperature or season.

5) In cold season, in order to start the engine easily, the tractor can be stored in a warm storehouse.

## **7. Maintenance for storage of a long period**

The tractor for storage of a long period should be fully examined on its technical condition; the tractor whose technical condition is perfectly normal can be put into the storehouse.

1) Store the tractor in dry storehouse; support the front and rear wheels off the ground with wood pieces. If storing in the open air for limited condition, cover the tractor with tarp and dig drains around the tractor. The place for storing should be far away from fire (kitchen house, oil depot and etc.)

2). Clean the outside of the tractor and lubricate each lubrication point with grease according to table 2-1.

3). Drain out the cooling water, dismount the battery for storage and cover the exhaust manifold mouth well.

4). Start the engine to run for 20 minutes every three months to see whether the tractor is in normal condition.

## ter IV AChapadjustment of Tractor

### 1. Adjustment of clutch

Due to continuous wear of parts during operation of the clutch, clutch slip and clutch incomplete disengagement will happen, which can't make the tractor work normally; therefore adjustment of clutch should be timely made.

#### 1) Adjustment of dual stage clutch

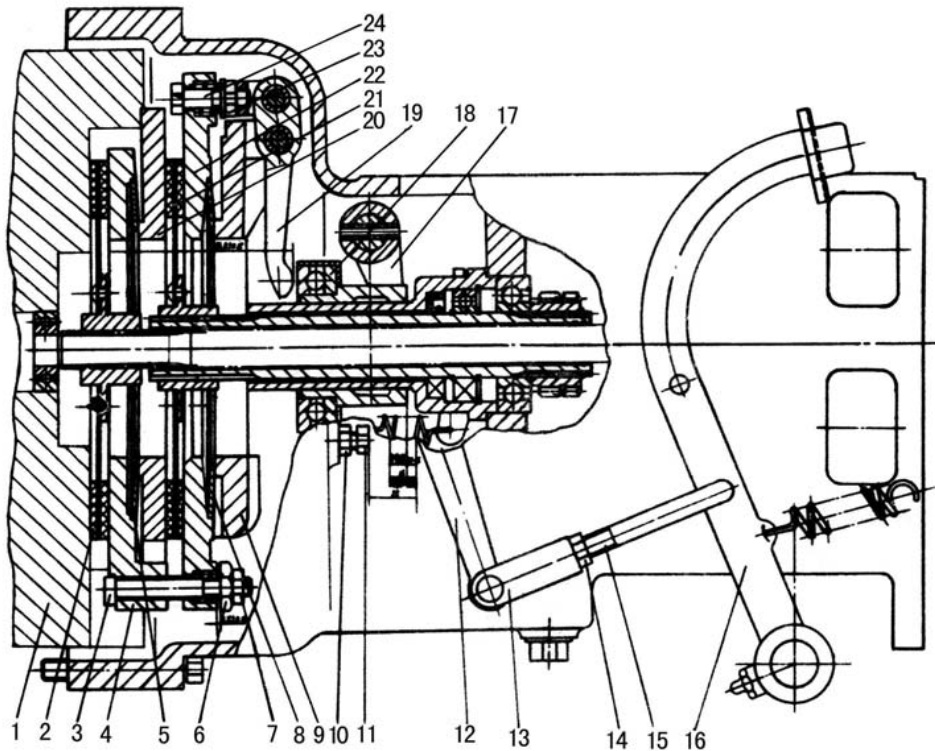

Fig.4-1 Dual stage clutch

1.Flywheel 2.PTO clutch driven plate 3.Pull rod 4.PTO clutch pressure plate 5.Belleville spring 6.Adjusting nut  
7.Nut 8.Belleville spring 9.Clutch cover 10.Nut 11.Adjusting bolt 12.Release rock arm 13.Release yoke  
14.Nut 15.Release yoke push rod 16.Clutch pedal 17.Release fork 18.Release bearing 19.Release yoke  
20.Fixed pressure 21.Main clutch driven plate 22.Main clutch pressure plate 23.Nut 24.Adjusting but

Fig. 4-1 is connection-controlled dual stage clutch. It mainly consists of three parts: driving part, driven part and controlling part. Driving part rotates with the engine flywheel; only when the clutch engages can the driven part rotate with the engine.

Dual stage clutch should be adjusted on a fixture. The adjusting steps are as follows: Adjust the length of adjusting bolt (11) to make the distance between 3 release levers (19) and the end faces of PTO clutch pressure plate (4) is 96.8mm, and the distance difference between 3 release levers and PTO clutch pressure plate is no more than 0.1mm; after adjustment tighten it with nut M10 × 1.

When adjusting the free travel of the clutch pedal (Fig. 4-1), firstly adjust the length of clutch push rod (15) to ensure that the clearance between end faces of three release levers and release bearing is  $2.5 \pm 0.5\text{mm}$  and the idle travel of release rock arm is 3.5-5mm; after adjustment tighten it with nut M10.

Position limit adjustment of working travel of clutch pedal: loosen nut (10), then turn adjusting bolt (11) to make the working travel under release rock arm (12) is 25mm, then tighten nut (10).

## 2) Adjustment of single stage clutch

Fig.4-2 is single - disk and dry single stage clutch . It is made up of clutch spring(1), clutch driven plate(2) ,clutch pressure plate(3) ,release lever(6) ,adjusting nut (7) ,release bearing (9) and its operation mechanism.

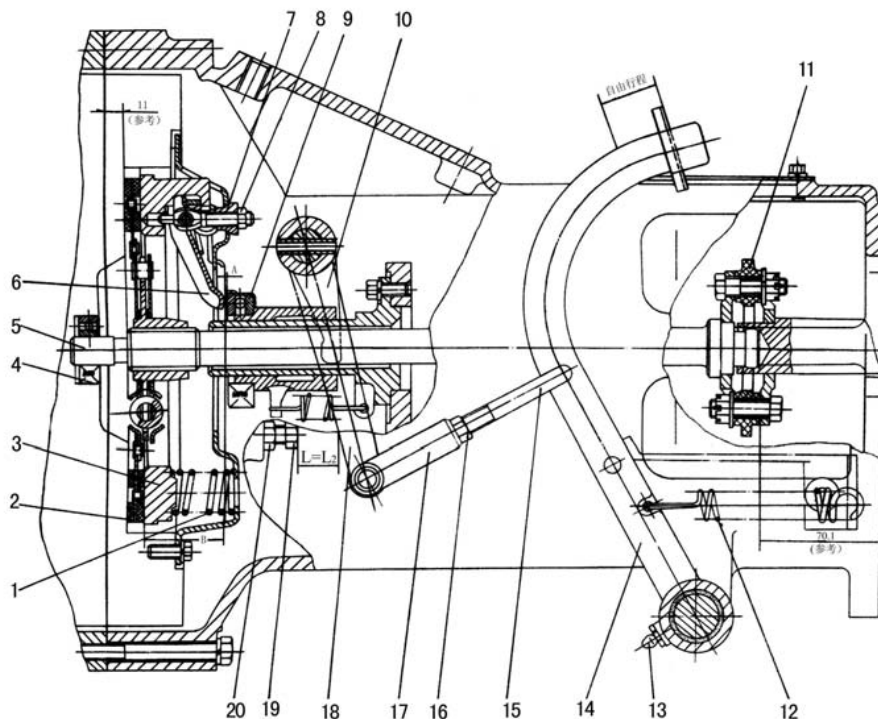

Fig.4-2 Single stage clutch

1.Clutch spring 2.Clutch driven plate 3.Clutch pressure plate 4.Rolling bearing 60203 4.Rolling shaft 6.Release lever 7.Adjusting nut  
8.Locking nut 9.Release bearing 10.Release fork 11.Pedal returning spring 12.Grease nipple 13.Clutch Pedal 14.Clutch push rod  
15.Locking nut 16.Clutch push rod adjusting fork 17.Clutch release rock arm 18.Limiting adjusting bolt 19.Locking nut 20.Coupling

The adjusting methods of single stage clutch are as follows:

### A. Position adjustment of release levers

In reassembling the clutch,turn adjusting nut(7) to make the distance between working

faces of release levers and the working face of pressure plate be  $B=45\text{mm}$ . When the clutch engages, the gap  $A=2-3\text{mm}$  between release bearing (9) and release levers (6) should be kept; and 3 working faces of the release levers (6) should be in the same plane, the allowed deviation is  $0.25\text{ mm}$ .

#### B.Free travel adjustment of clutch pedal

Turn push rod adjusting fork (16) to change the effective length of push rod (14) until it reaches the free travel of the clutch pedal  $L=8-12\text{ mm}$  (while the corresponding free travel under the release rock arm (17) is  $L_1=3.5-5.5\text{ mm}$ ).

#### C. Position limit adjustment of working travel of clutch pedal

Turn limiting adjusting bolt (18) until the working travel under release rock arm(17) is  $L_2=13-17\text{mm}$ . In operation the free travel of the clutch pedal should be often checked and ensured.

## 2. Adjustment of main drive

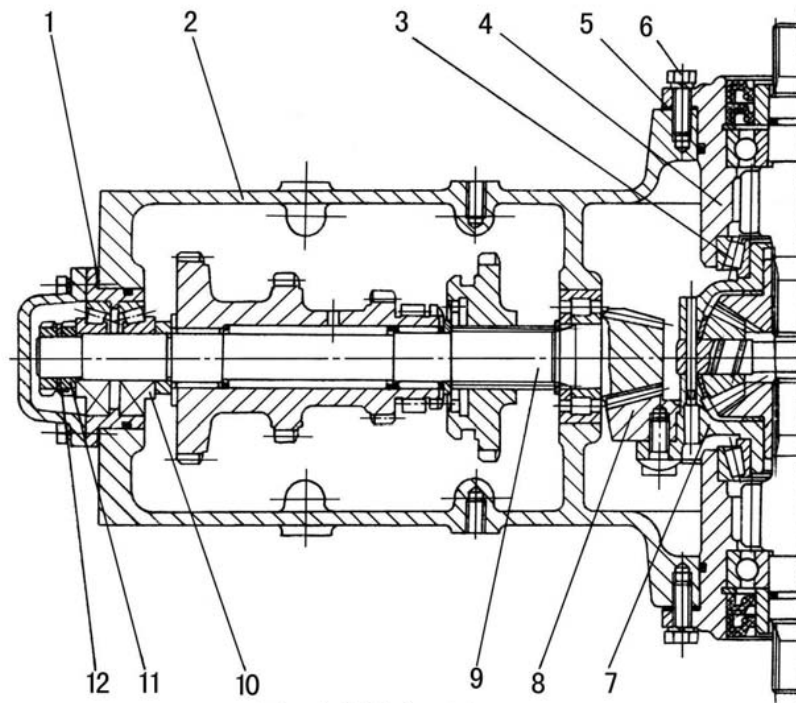

Fig.4-3 Main drive

- 1.Adjusting shim 2.Transmission case 3.Conical bearing 2007111 4.Bearing seat  
5.Adjusting shim 6.Bolt 7.Differential case 8.Driven conical gear 9.Second shaft  
10.Conical bearing 27305 11.Locking slice

#### 1)Preload adjustment of the conical bearing

During assembling there should be some preload on two conical bearings (3) 2007111 (on two ends of differential) and two conical bearing 27305(10) (on second shaft) (Fig.4-3) for

reducing axial displacement and increasing supporting rigidity of the spiral bevel gears under operation. After operation for a period, as the conical bearings wears, the former preload will disappear gradually, and moving clearance will occur between the two conical bearings when the two moving clearance is more than 0.1 mm, the conical bearings should be preloaded again.

#### **A. Preload adjustment of second shaft conical bearing**

Adjust the screwing tightness of the locking nut (11) near the bearing until the torsional friction torque of the second shaft (9) is 0.7-1.1 N.m. After adjustment, insert locking slice (12), then tightly screw the second locking nut (11).

#### **B. Preload adjustment of differential conical bearing**

Insert the adjusting shims (5) in same quantities between the two sides of transmission box (2) and the bearing seats (4) of conical bearings, then tightly screw the bolts (6) of the bearing seats; and turn second shaft (9), if the torsional torque is 0.4-0.76 N.m more than that of the condition that the differential is not mounted, then the preload is suitable. In such case, any axial displacement of the crown gear should not exist with the axially applied thrust.

### **2) Adjustment of meshing prints and backlash of the spiral bevel gears**

#### **A. Standard of meshing backlash and meshing print**

The required mesh backlash is 0.1-0.25 mm. The ideal mesh prints distribute in the middle of the working teeth surface and are slightly near the small end of the teeth; meshing prints are like spots; meshing print height is not less than 50% of tooth height, the length of meshing print is not less than 60% of tooth length.

#### **B. Inspection of mesh backlash and mesh print**











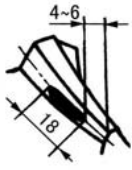

##### **a. Inspection of mesh backlash**

There are two methods of inspection: One is dial gauge inspection. During measuring, put contact terminal on the teeth surfaces of big ends of bevel gear, and fix bevel pinion, swing bevel gear in rotating direction; if the reading of the dial gauge is 0.14-0.3mm(circular clearance), the backlash is correct. The other method is as follows: Using a lead wire of 15-20mm long and 0.5mm thick or a fuse bent into " ∞ " shape, put it between the unmeshed teeth surfaces of the bevel gear and pinion(i.e. between the convex surface of the bevel pinion and the concave surface of the bevel gear) and rotate the gear pair, then the thickness of the extruded part where the lead slice is near the big ends of the gears is the vertical gear backlash. The gear backlash should be among the range of 0.1-0.25mm(vertical backlash). It is better to measure three or more points well distributed along the circumference of the bevel gear and take the average value of measuring the gear backlash in the three or more points.

##### **b. Inspection of mesh print**

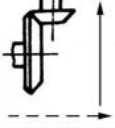
Coloring method is adopted in the inspection of the mesh print. Smear red-lead paint evenly on the faces of the bevel gear teeth. Turn the bevel gears several times until the distinct contact traces are imprinted on the teeth faces of the bevel pinion. The print imprinted on the teeth faces of the bevel pinion is mesh print. As the spiral direction of the bevel pinion is right-handed, when the tractor forwards, the force is applied on the concave face of the bevel pinion, the redlead paint should be smeared on the convex face of the bevel gear; while the tractor reverse, the force is applied on the convex face of the bevel pinion, the red-lead paint should be smeared on the concave face of the bevel gear.

**Table 4-1 Adjustment of mesh print of bevel gear**

Forward 	Reverse 	Adjusting method	
		Normal mesh print	During forwarding, the length of mesh print of the concave faces is not less than 60% of the tooth width, the height is not less than 50% of the tooth height. Correct mesh print distributes evenly in the middle and near the small end of the tooth. During reversing, the mesh print of the convex faces of the bevel pinion is the same with the above condition.
			Reduce adjusting shim (1) of second shaft to make bevel pinion move backward. See Fig.4-3.
		Add Adjusting shim (1) of second shaft to make bevel pinion move forward.	
		Abnormal mesh print	Add adjusting shim (5) of the right side of bevel gear and reduce adjusting shim (5) of the left side of the bevel gear in the same quantity to make the bevel gear move right.
			Add adjusting shim (5) of the left side of bevel gear and reduce adjusting shim (5) of the right side of the bevel gear in same quantity to make the bevel gear move left.

**Note:** solid line arrow shows the adjustment of mesh print and dotted line shows the adjustment of mesh backlash.

### c. Adjustment of mesh backlash and mesh print

During adjustment, the bevel gear and pinion axially moving will change both mesh backlash and mesh print. If the mesh print requirement is contradictory to mesh backlash, correct mesh print should mainly be ensured, and the adjustment range of mesh backlash can be enlarged (Especially when the gear and bearing wears and the readjustment is needed, the backlash can be enlarged). But the mesh backlash should be not less than 0.1mm.

During normal operation of the tractor, the normal mesh backlash and mesh point will both change, under this condition, so long as teeth faces contact is normal, only the mesh backlash increases, and this increase of backlash due to gear wear need not be adjusted. But after the overhaul of the tractor or when replacing a new pair of main drive gears or bevel bearing, the mesh print and backlash should be ensured at the same time by careful adjustment.

**Note:** As the bevel pinion and the bevel gear are a pair of matched gears, be sure not to make pairs in disorder. The spiral bevel gears should be replaced together with the bearings, if possible. Otherwise, it will affect their service life.

## 3. Adjustment of differential lock

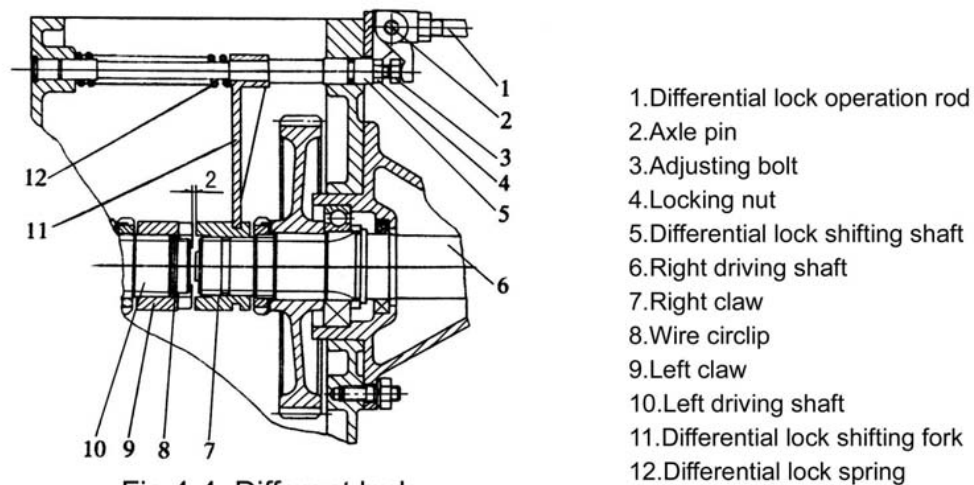

Fig.4-4 Different lock

The differential lock can be adjusted through bolt (3) and nut (4). During adjusting, the gap between left claw (9) and right claw (7) should be about 2mm. Screw in or out the bolt (3) to increase or reduce the gap. After the adjustment has been done, use nut (4) to tighten bolt (3). (Fig.4-4)



## 4. Adjustment of brake

After the tractor has worked for a period, the wear of the friction disc of the brake makes the gap between friction disc and brake drum or friction disc and brake case and brake cover increase and affect the brake performance. Excessive free travel will cause brake ineffectiveness. So the brake should be regularly adjusted to ensure the safety walk of the tractor. When one of the following faults of the brake appears, adjustment should be done in time. (No matter the tractor is new or old).

- a. Free travel of brake pedal is excessive and cause brake ineffectiveness.
- b. Free travel of brake pedal is too small and keep the brake in semi-braking state; the brake case also generates heat.
- c. Left and right braking force is unidentical and tractor yaw motion appears.

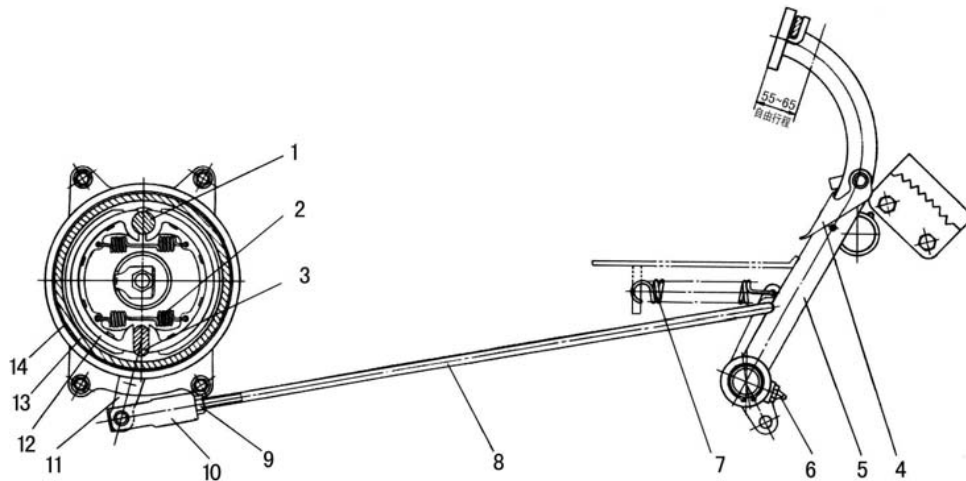

Fig.4-5 Block brake

- 1.Axle pin 2.Returning spring 3.Brake cam 4.Pedal brake claw 5.Brake pedal 6.Grease nipple(greaser)
- 7.Returning spring 8.Brake pull rod 9.Locking nut 10.Pull rod adjusting fork 11.Brake rock arm
- 12.Brake shoe 13.Brake drum 14.Brake case

### 1)Adjustment of block brake(shoe brake)

A. Free travel adjustment of brake pedal is the displacement measured from the highest position of the pedal ,when resistance is felt by pressing the pedal .The travel should be in the range of 55-65 mm (Fig.4-5) .During adjustment ,firstly loosen the locking nut (9) on brake pull rod (8) and change the length of the brake pull rod ,then press the brake pedal (5) from its highest position untill the displacement it 55-65mm and the gap between brake drum (13) and brake shoe(12) is eliminated . Make the left and right brake pull rod adjustment be identical ,the tighten them with locking nut (9) (Fig.4-5).

### B.Tractor yaw motion adjustment

While left and right brake adjustment is unidentical and the tractor running in high speed is braked in emergency , unidentical tyre print length (left and right ) and yaw motion appear .In such case ,the brake pull rod should be shortened in the side with short print length of tire ,or vice versa, to make both sides of the driving wheels to be braked simultaneously and reliably ,then retighten the locking nut (9) . Subsequently ,check in the 3rd gear firstly ,after above adjustment has been done ,the check in the 4th gear again.

## 2) Adjustment of disc brake

A. Free state adjustment of disc brake pedal is the displacement measured from the highest

Loosen the outer locking nut M10 (5) on adjusting rod (1) and turn the inner nut M10 (4) to change the mounting angle of the rock arm (2) through the longitudinal motion of the self-position cushion (3) and ensure that the central connecting line of the upper and lower holes inclines to rear from the plumb line. After adjustment, lock it with locking nut (5). (Fig.4 -6)

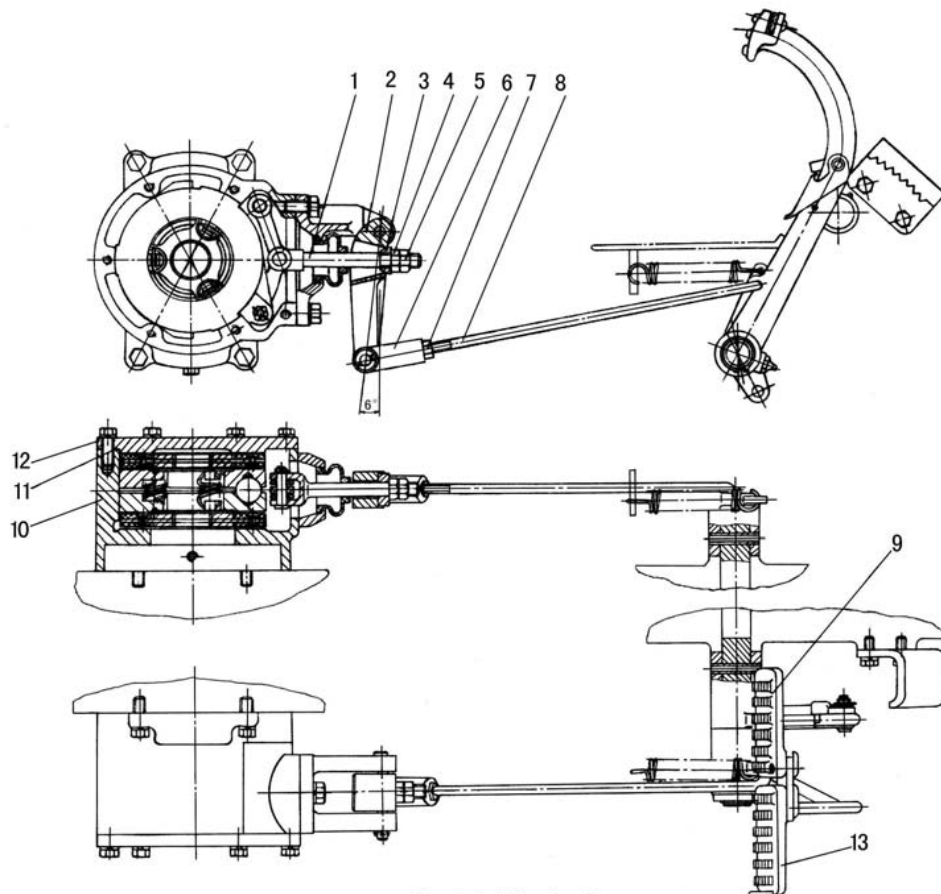

Fig.4-6 Disc brake

- 1.Adjusting rod 2.Rock arm 3.Self-position 4.Nut M10 5.Nut M10 6.Brake pull rod adjusting rock 7.Nut M8  
8.Brake pull rod 9.Left brake pedal assembly 10.Brake case 11.Brake cover gasket 12.Brake cover  
13.Right brake pedal assembly

### B. Travel adjustment of brake pedal

Loosen the locking nut (7) on pull rod adjusting fork (6) and turn brake pull rod adjusting fork to change the length of the pull rod (8) until the displacement (from the highest position of the brake pedal to friction disc assembly being completely braked) of the brake pedal is 85-95mm. When the left and right pedal are locked together, stepping on the pedals can simultaneously brake the left and right wheels; after adjustment, lock it with nut (7). (Fig.4-6)

If the above adjusting range can not perfectly make the free state and brake state out, they can be adjusted through increasing or reducing the brake cover gaskets (11) between brake cover (12) and brake case (10). If the brake travel is too small, increase the gaskets; if the brake travel is too big, reduce or remove the gaskets. (Fig.4-6)

### C. Brake yaw motion adjustment

Refer to the adjustment of shoe brake

## 5. Adjustment of front axle

### 1) Axial clearance adjustment of front wheel bearings

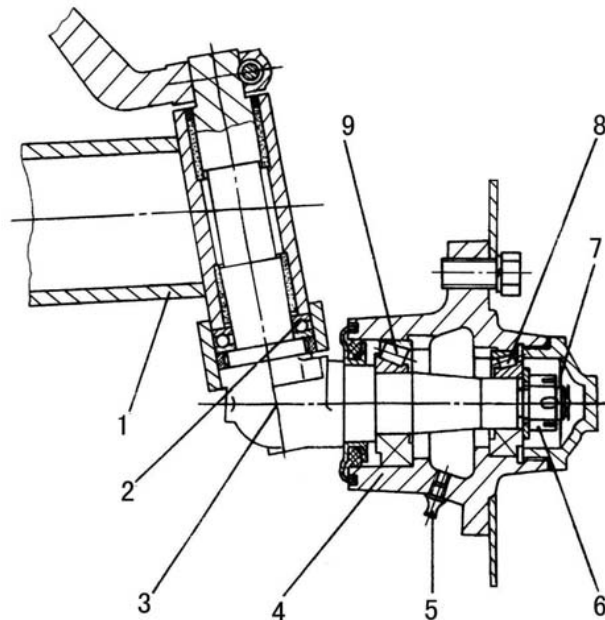

Fig.4-7 Front wheel hub and steering knuckle

1.Front axle 2.Bearing 8106 3.Steering knuckle 4.Front wheel hub  
5.Greaser 6.Nut 7.Split cotter 8.Bearing 7205 9.Bearing 7206

The normal axial clearance between front wheel bearings (8) and (9) is 0.1-0.2mm(Fig.4-7). During operation, when the clearance is more than 0.4mm, the front wheel will swing to left or right during walking; and the bearings are easily broken by shock load, so adjustment

should be made timely. During adjustment, firstly support the front wheels off the ground, and dismantle the bearing cover and pull out the split cotter on nut (6), then screw nut (6) until the bearing clearance is eliminated, and return the nut (6) in 1/15-1/7 turn, then lock the nut with split cotter, and assemble the bearing cover.

## 2) Adjustment of front wheel toe-in

During the operation of the tractor, the front wheel toe-in will change due to deformation and wear out of the parts of steering mechanism and front axle. If the toe-in is not adjusted in time, the wear of the front wheel will accelerate. The adjustment steps of toe-in are as follows:

a. Stop the tractor on level ground, place the front wheels on rectilinear walking position.

b. Measure the distance A and B between the two wheels (Distance A is the distance between the forefront of the two wheels. B is the distance between the rearmost ends of the two wheels.) at the same horizontal plane through the centers of the two wheels circumference.

c. Loosen the locking nuts (1) and (3) on both sides of the knuckle rod (2); turn the knuckle rod to make  $B-A=4-10\text{mm}$ , then retighten knuckle rod (2) with nuts (1) and (3).

## 6. Adjustment of front drive axle

### 1) Adjustment of main drive (Fig.4-9)

During assembling, choose the suitable bearing seat gasket (9) of driving bevel gear and adjust the adjusting nuts (3) on the both sides to make the mesh backlash of the gear pairs of the main drive be 0.15-0.30mm, and ensure the contacting area, i.e. the meshing contact traces of the gear pairs should be

adjusted to the middle of gear tooth faces and slightly nearer to the small end; and should also ensure that no axial movement of the bearings on either end will appear, and that the differential assembly could turn freely. Adjust the position of the concave slot of the nut to make the locating plate of the cover be inserted smoothly, then lock the nut.

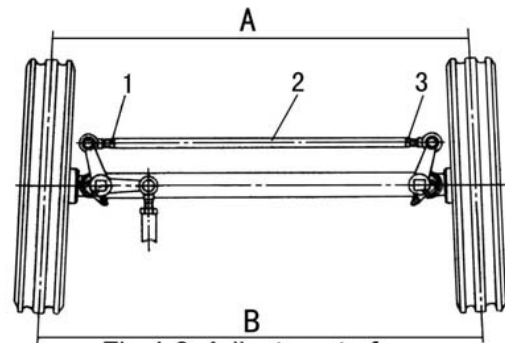

Fig.4-8 Adjustment of front wheel toe-in

- 1.Right-handed nut
- 2.Knuckle rod
- 3.Left-handed nut

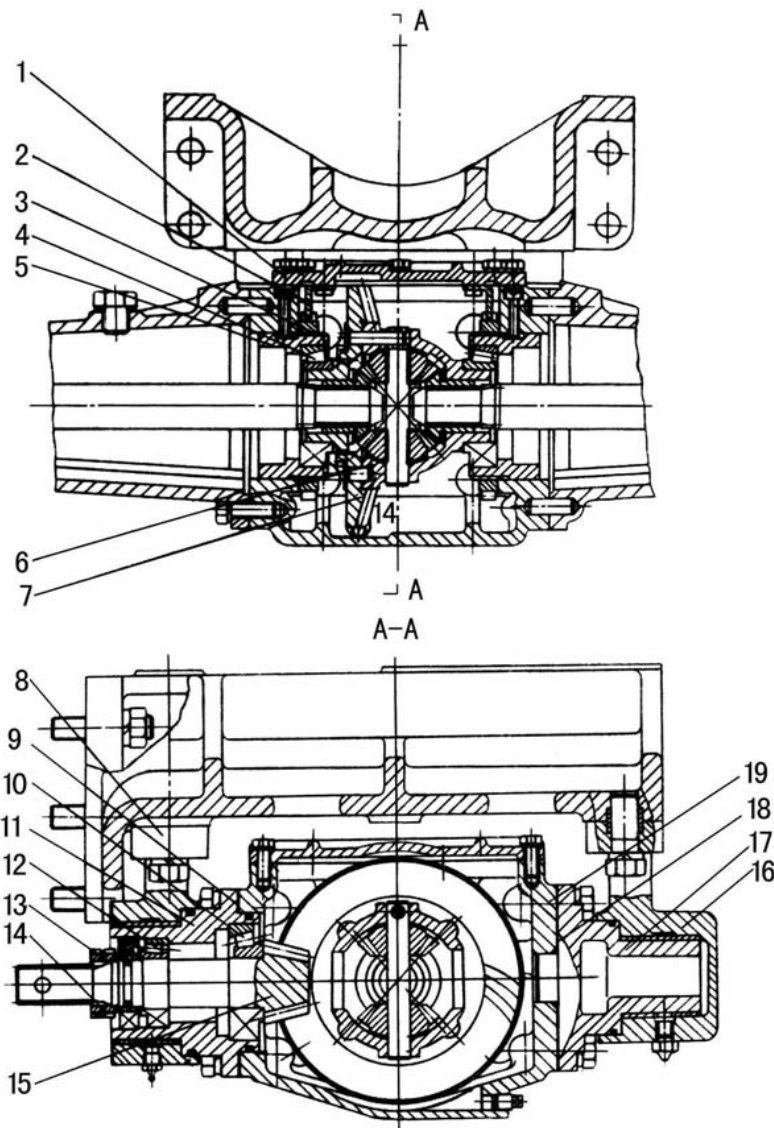

Fig.4-9 Main drive of front drive axle and differential assy

- 1.Upper cover of main transmission box 2.Locking slice 3.Adjusting nut  
 4.Rolling bearing 2007109 5.Bearing seat 6.Differential case 7.Driven level gear 8.Rear support seat 9.Bearing seat gasket 10.Rolling bearing 27306 11.Bearing seat of driving level gear 12.Rolling bearing 2007106 13.Circular nut 14.Stop washer 15.Driving level gear 16.Front support seat 17.Front pendulum shaft 18.Gasket of front pendulum shaft 19.Main drive case

## 2) Adjustment of side reduction gear pairs (Fig.4-10)

During assembling, choose gasket (13) of driving shaft cover to keep the mesh backlash of side reduction gear pairs among 0.2-0.4mm, and ensure meshing contact traces.

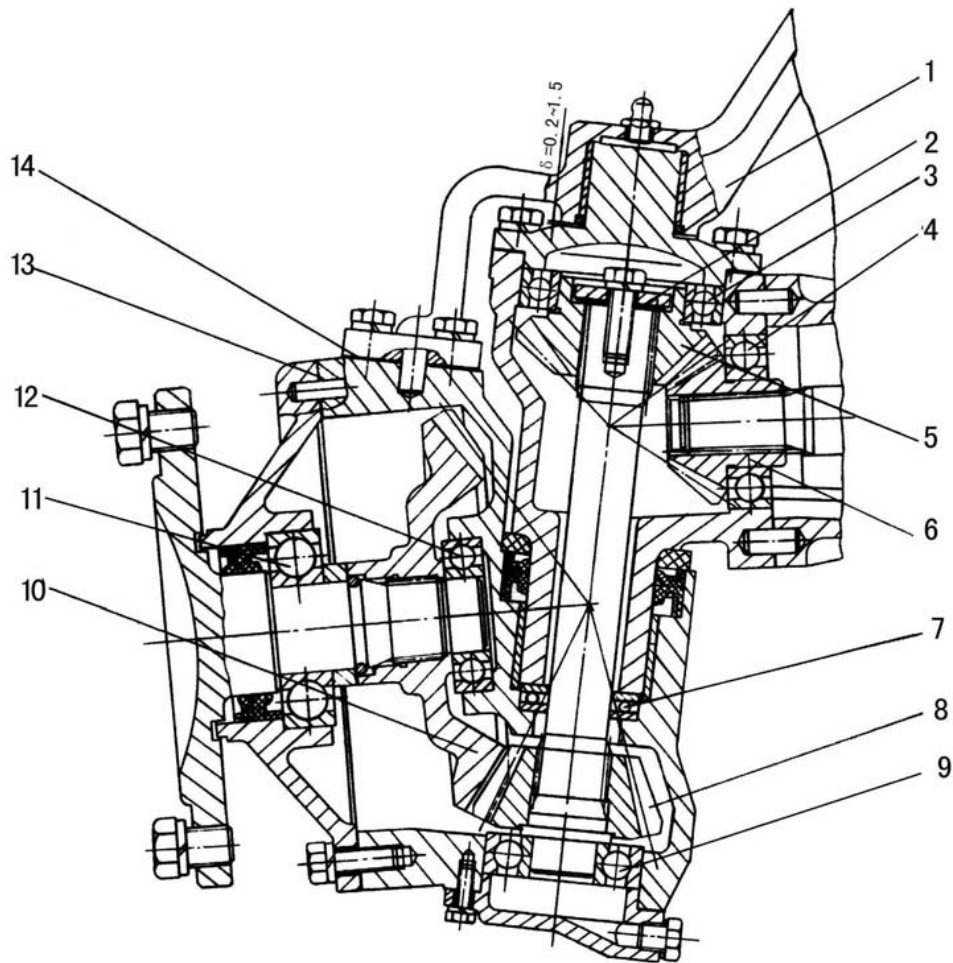

Fig.4-10 Final trasmission of front drive axle

- 1.Left steering knuckle 2.Adjusting shim of standing shaft 3.Rolling bearing 110  
 4.Rolling bearing 207 5.Driven gear of intermediate transmission 6.Driven gear of  
 final transmission 7.Rolling bearing 8106 8.Driving gear of final transmission  
 9.Rolling bearing 305 10.Driven gear of final transmission 11.Rolling bearing 307  
 12.Rolling bearing 206 13.Gasket of driving shaft cover 14.Adjusting shim

### 3) Adjustment of intermediate driven gear pairs (Fig.4-9)

During assembling, choose adjusting shim (2) of the standing shaft to keep the mesh backlash among 0.2-0.4mm and ensure meshing contact traces.

## 7. Adjustment of wheel tread

### 1) Adjustment of front wheel tread

The front wheel treads of Agracat Series Tractors have the following two types: adjustable wheel tread and non-adjustable wheel tread. The adjustable wheel tread is adjusted in step through extension sleeve housing. The adjusting range is 970-1270mm. Every step clearance is 100mm.

## 2) Adjustment of rear wheel tread

The wheel tread of the back wheels can be steplessly adjusted through changing or turning over the fixed position of the driving wheel hubs in the driving shaft. It can be also adjusted in steps through turning over the wheel rims or exchanging the right and left driving wheels.

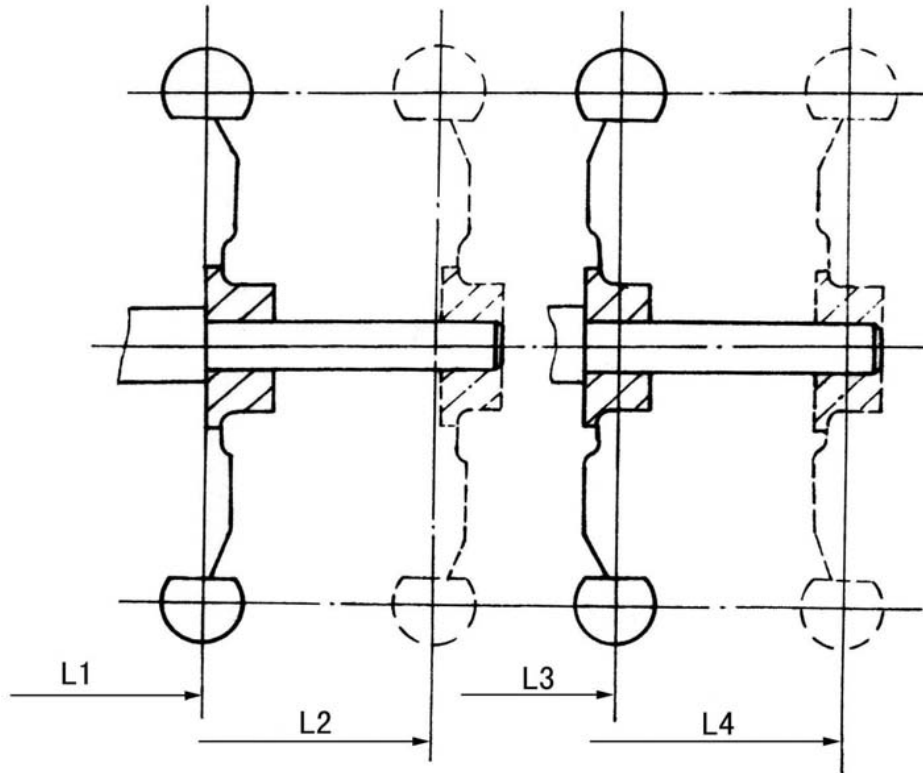

Fig.4-11 Adjustment diagram of rear wheel tread

The adjustment range of the first-step wheel tread is L1-L2; the normal wheel tread is L2. The adjustment range of the second-step wheel tread is L3-L4 (see Fig.4-11). Numerical value of L1-L4 can be referred to in chapter I .

## 8. Adjustment of steering gear

There are three kinds of steering gear of Agracat Series Tractors: crankpin type (Fig.4-12), circulating ball type (Fig.4-13) and hydraulic steering gear (Fig.4-14).

### 1) Adjustment of crankpin type steering gear (Fig.4-12)

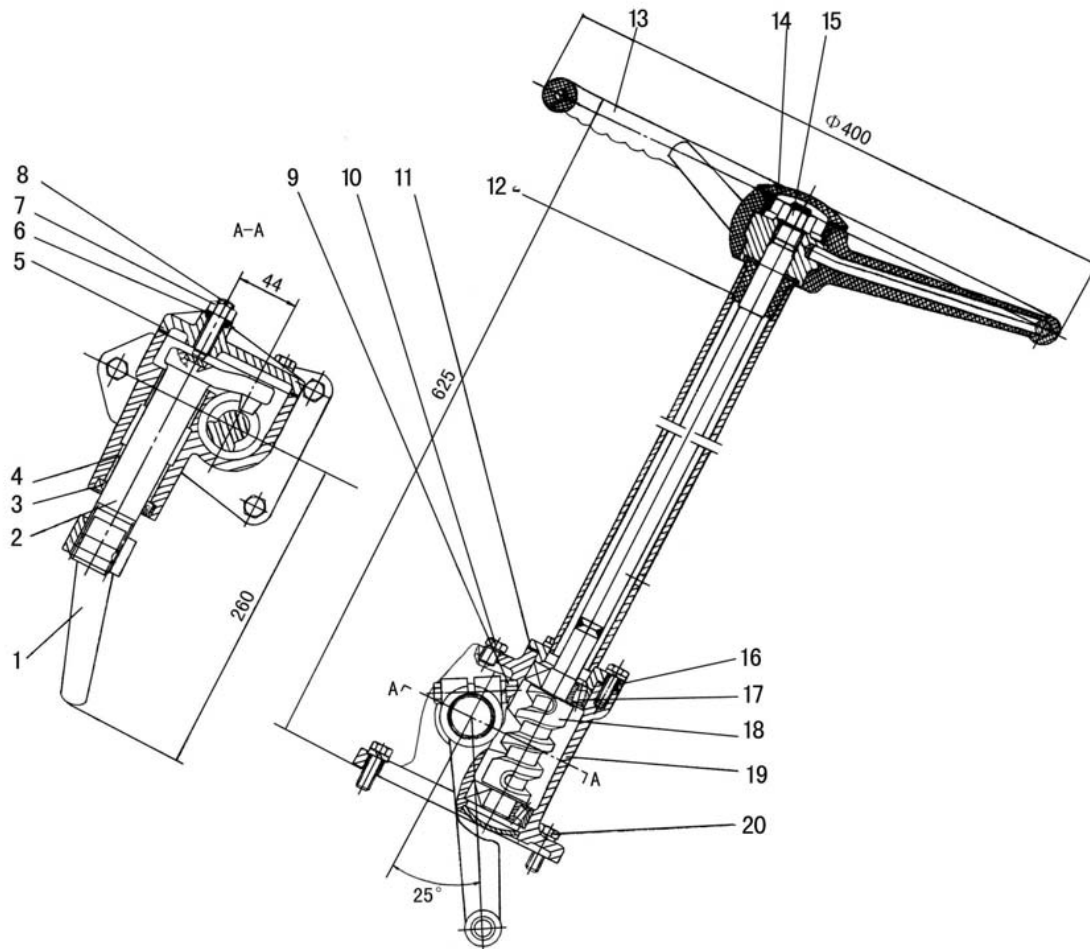

Fig.4-12 Crankpin type steering gear

1.Rock arm 2.Rock arm shaft 3.Oil seal PD30×45×8 4.Bush 5.Side cover 6.Washer 7.Nut 8.Adjusting screw  
9.Bolt 10.Screw plug 11.Adjusting washer 12.Upper oil seal 13.Steering wheel 14.Steering wheel cover 15.Nut  
16.Steering column 17.Rolling bearing 7204 18.Steering worm 19.Steering housing 20.Nut

#### A. Adjustment of bearing clearance

In order to ensure the normal work of the steering gear, the clearance of the bevel bearings 7204 on either end of steering worm should be adjusted. When the bearings wear out to make the axial clearance increase, the clearance should be adjusted timely; i.e. make the upper and lower moving play of the steering worm be not more than 0.1mm through increasing or reducing the quantity of adjusting shim (11).

#### B. Adjustment of mesh clearance of steering worm and crankpin

During operation, the mesh clearance will increase due to the wear out of the steering worm and crankpin, and the idle angle of the steering wheel also increases. When the idle angle of the steering wheel is more than  $25^{\circ}$  (or the arc length along the outside of the steering wheel is more than 90mm), the clearance should be adjusted.



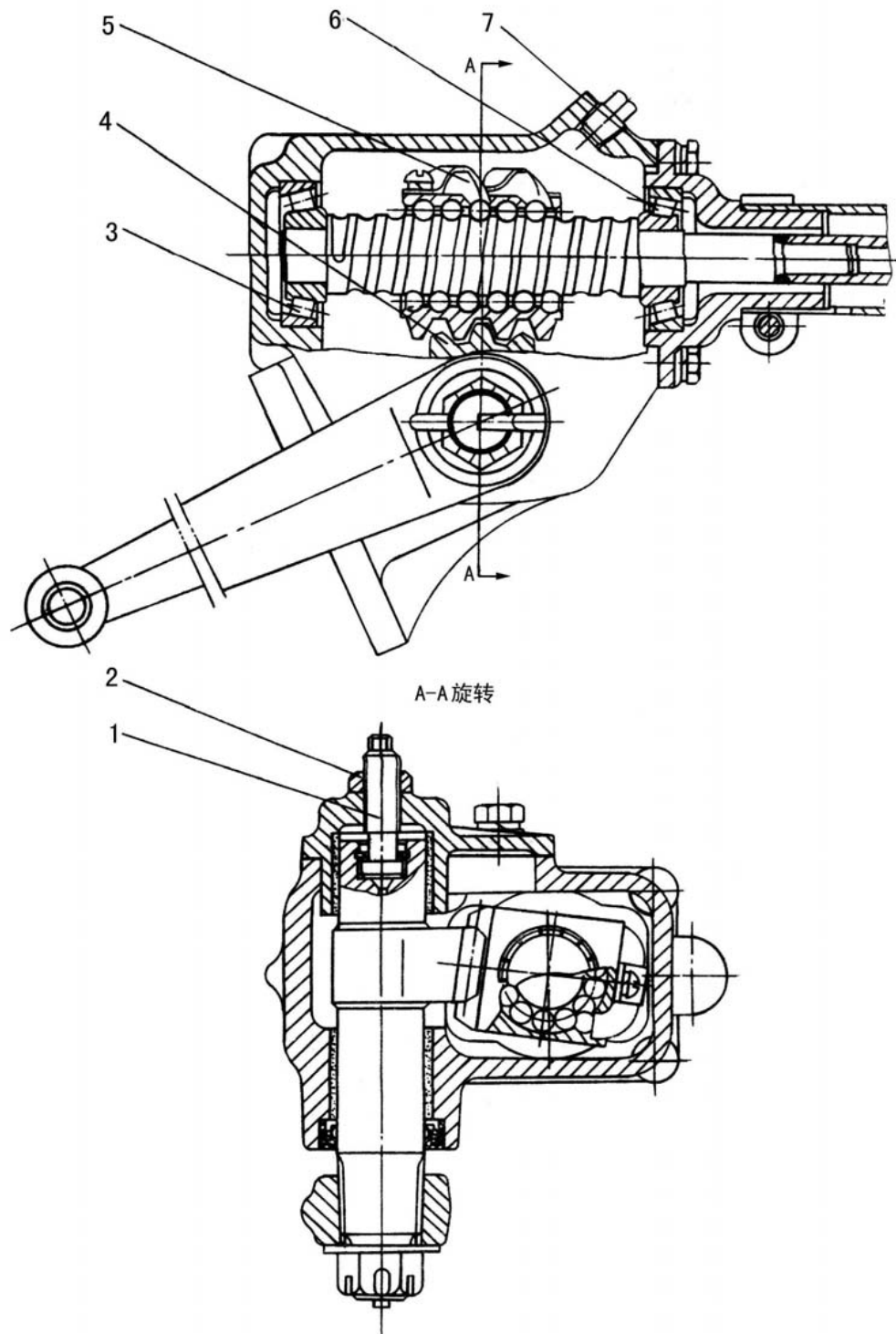

Fig.4-13 Circulating ball type steering gear

1.Adjusting screw 2.Nut 3.Rolling bearing 7304 4.Rock arm shaft 5.Steering rock arm shaft and steering worm and nut assembly 6.Rolling bearing 7304 7.Adjusting shim

**Adjusting method:** loosen nut (7), turn adjusting screw (8) to make rock arm shaft (2) move axially and therefore the mesh clearance is changed.

When the rock arm shaft is in middle position, the free travel of steering wheel outside is 50-55mm, i.e. the idle angle of the steering wheel is no more than  $15^\circ$ , then the adjustment is suitable. After adjustment, lock nut (7).

## **2) Adjustment of circulating ball type steering gear**

### **A. Adjustment of bearing clearance**

In order to ensure the normal work of the steering gear, the clearance of the bevel bearings 7304 on both ends of the rock arm shaft should be adjusted. When the bearings wear out and the axial clearance of the bearings increases, the clearance should be adjusted in time; i.e. make the upper and lower moving play of the steering worm be not more than 0.1mm through increasing or reducing the quantity of adjusting shim (7).

**B. Adjustment of mesh clearance of rock arm shaft (with steering worm and nut assembly) and fan teeth of rock arm shaft.**

During operation, the mesh clearance will increase due to the wear out of fan teeth of the rock arm shaft (with steering worm and nut assembly) and the idle angle of the steering wheel will also increase; so adjustment should be made in time. Loosen nut (2), turn adjusting screw (1) to make rock arm shaft move axially and therefore the above mesh clearance is changed.

## **3) Construction and adjustment of balance string type hydraulic steering gear**

**A. Working principle of balance string type hydraulic steering gears** BZZ series balance string type hydraulic steering gears are adopted in the hydraulic steering gears of Agracat series tractors; their structure diagram is as Fig.4-14. It is mainly made up of steering control valve and steering measuring device.

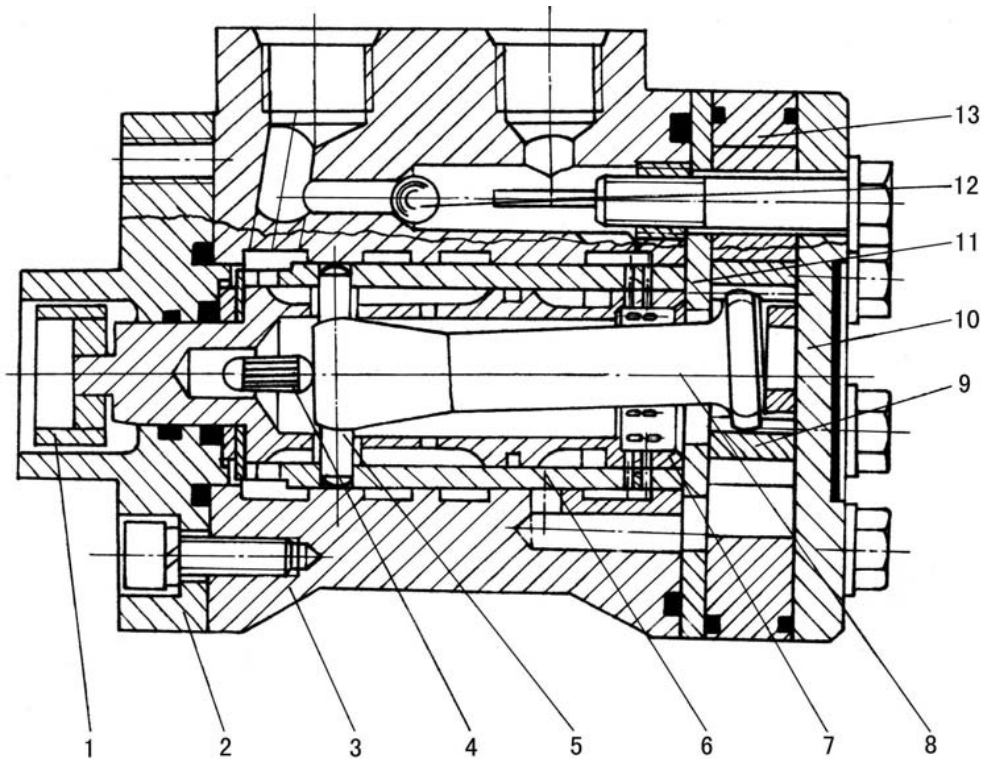

Fig.4-14 Balance string type hydraulic steering gear

1.Connecting piece 2.Front cover 3.Valve body 4.Spring leaf 5.Plug 6.Valve sleeve 7.Valve core  
8.Connection shaft 9.Rotor 10.Rear cover 11.Spacer plate 12.Steel ball 13.Stator

Valve sleeve of the steering control valve (6) is connected with valve core (7) through plug (5), and spring leaf is fixed in the middle of the valve. The hole in the valve core (for mounting the plug) is a little bigger than the hole in valve sleeve (6), so they can rotate relatively, the outside of the valve core connects with connecting piece (1).

The stator (13) and rear cover (10) of steering measuring device are fixed together with valve body (3) of steering control valve by bolt. Rotor (9) connects with valve sleeve (6) through connection shaft (8) and plug (5). Rotor (9) and stator (13) are balance string type needle wheel mesh pair. The rotor has 6 short outer pendulum string curve teeth of equal distance, while the stator has 7 arc needle teeth. During working, the stator is still and the rotor rotates round the center of the stator at the radius of a certain eccentric distance. When the rotor rotates round center of the stator (revolution), it also rotates round its axial line in opposite direction (rotation). As the rotor makes a circuit and it can rotates round the stator center for  $-6/(7-6)=-6$  circuits, rotor makes one circuits, the oil liquid will be squeezed out from the teeth slot ( $6 \times 7=42$ ), and the displacement at unit volume is large.

#### B. Adjustment of balance string type hydraulic steering gear.

As the rotating times or circuits of the steering wheel concern the rated displacement of

the steering gear, which has been decided during designing; if the radial or axial clearance of the stator and rotor pair is too big to cause no manpower steering, then the rotor and stator pair should be replaced. In other conditions, adjustment is not needed.

## 9. Construction and adjustment of hydraulic hitch system

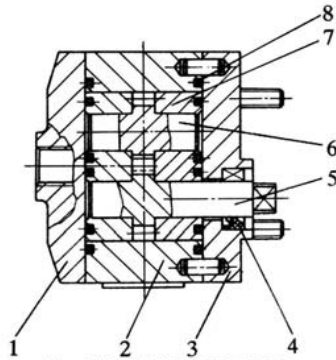

Fig.4-15 CBN-E 306-X1 Gear pump  
1.Rear cover 2.Pump body 3.Front cover  
4.Oil seal 5.Driving gear 6.Driven gear  
7.Shaft sleeve 8.Seal ring

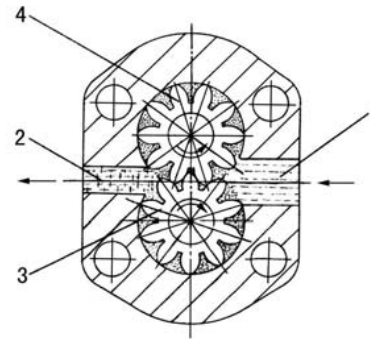

Fig.4-16 Working principle diagram of gear pump

1.Suck oil cavity 2.Pressure oil cavity  
3.Driving gear 4.Driven gear

Hydraulic hitch system consists of hydraulic system and hitch device. Hydraulic system is an open circulating circuit system controlled by pressure circuit. The hitch device is rear-attached 3 point hitch. Hydraulic system mainly consists of semi-separation attachment type hydraulic lifter, gear pump, oil filter and their oil pipes (which connect them together).

### 1) Working principle of gear pump

The gear pumps attached to Agracat series tractors are CBN model volume type outside mesh gear pumps (Fig.4-15). They are all left handed pumps except the right handed pumps on Agracat-160, 164 tractors. The gear pumps are mounted on the back end face of the right side of the gear case of the diesel engine front, which are driven by engines. The gear pump is made up of a pair of outside mesh shaft gear (5) and (6), gear body (2), sleeve (7) and rear cover (1) and front cover (3).

The working principle of the gear pump is as Fig.4-16. Take left-handed gear pump as example: After starting the engine, the driving gear of gear pump rotates counterclockwise, and the oil enters the teeth from the pressure oil cavity and fill the teeth with oil. The oil entered the pump is surrounded and contained by sleeve, meshed teeth and pump body and two oil cavities which are not connected with each other are formed: suck oil cavity and pressure oil cavity. The gear rotates right cavity (suck oil cavity) and the inner gear teeth return mesh to make the volume between gear teeth increase and form part vacuum, and the oil in the tank is sucked in. Meanwhile the inner gear teeth of left cavity (pressure oil cavity) begin to mesh (teeth into each other) to squeeze the oil among the teeth out of the oil pump.

With the rotation of the engine, the oil in the cavity will continuously flow into the lifter through gear pump.

During working, there is pressure difference between the suck oil cavity and pressure oil cavity of the gear pump, the high pressure oil of pressure oil cavity will leak and return to the suck oil cavity along the clearance of the end faces of the gear and sleeve, gear tip and pump body and the clearance formed by bad gear mesh; which will cause pump volume loss and the heat of the hydraulic system. Too much volume loss will not make the gear pump form normal working pressure; if seriously, the gear pump can't lift the implements.

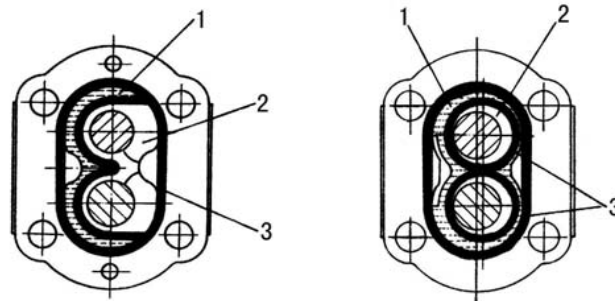

a) Gear pump with new structure      b) Gear pump with old structure  
 Fig.4-17 Hydraulic compensation diagram  
 1.High pressure work area 2.Low pressure work area 3.Seal ring press area

In order to reduce the volume loss of the gear pump, complete floating sleeve is adopted in the pump, which has hydraulic automatic compensation and axial balance construction. During working, the sleeve can float in the pump body; the position of the sleeve is decided by the force applied on the sleeve. The width of the pump body is 0.09-0.18mm bigger than the width sum of gear and sleeve. After mounting, the front and rear cover are pressed tightly on the pump body, the seal ring between the covers are compressed and the sleeve is pressed tightly on the two end faces of the gear, thus not big clearance forms between sleeve and covers. When the oil pressure in the gear rises, the oil pressure apply on the back of the sleeve through the clearance (Fig.4-17), which ensures the good cooperation of the sleeve and gear stick end faces. This action is called hydraulic automatic compensation.

## 2) Lifter

### A. Working principle of valve (simple direction exchange valve)

The structure and working principle of the simple direction exchange valve is as Fig.4-19.

Main control valve (1) can be respectively put on lifting, neutral and lowering positions through pulling operation handle (5). When main control valve (1) is on neutral position (Fig-4-19b), the oil from the oil pump into the direction exchange valve flows back into oil tank

through returning oil cavity A according to the flow direction designated by the arrow of the Fig4-19(b). Then the entering oil cavity B and returning oil cavity C of the cylinder are sealed by main control valve (1); the oil cylinder is on seal and lock condition, and the implements are maintained in the fixed position.

When the main control valve (1) is pushed to the lowering position (Fig.4-19d) from neutral position, the returning oil cavity C is opened, the oil in the cylinder is squeezed back into oil tank via returning oil cavity C under the action of the weight of the implement according to the flow direction designated by the arrow in the Fig.4-19d, then the implement is lowering. In such case the oil from oil pump into direction exchange valve still flows back into oil tank through returning oil cavity A.

When the main control valve is pushed to lifting position from neutral position (Fig.4-19c), the returning oil cavity A closes, while entering oil cavity B opens. Then the oil from oil pump into direction exchange valve enters the oil cylinder via oil cavity B according to the flow direction designated by the arrow in Fig.4-19c, and push the piston forward, then the implement begins to rise.

System safety valve is added and established in the direction exchange valve in order to prevent the hydraulic components from being damaged due to overload during the rising of the implement.

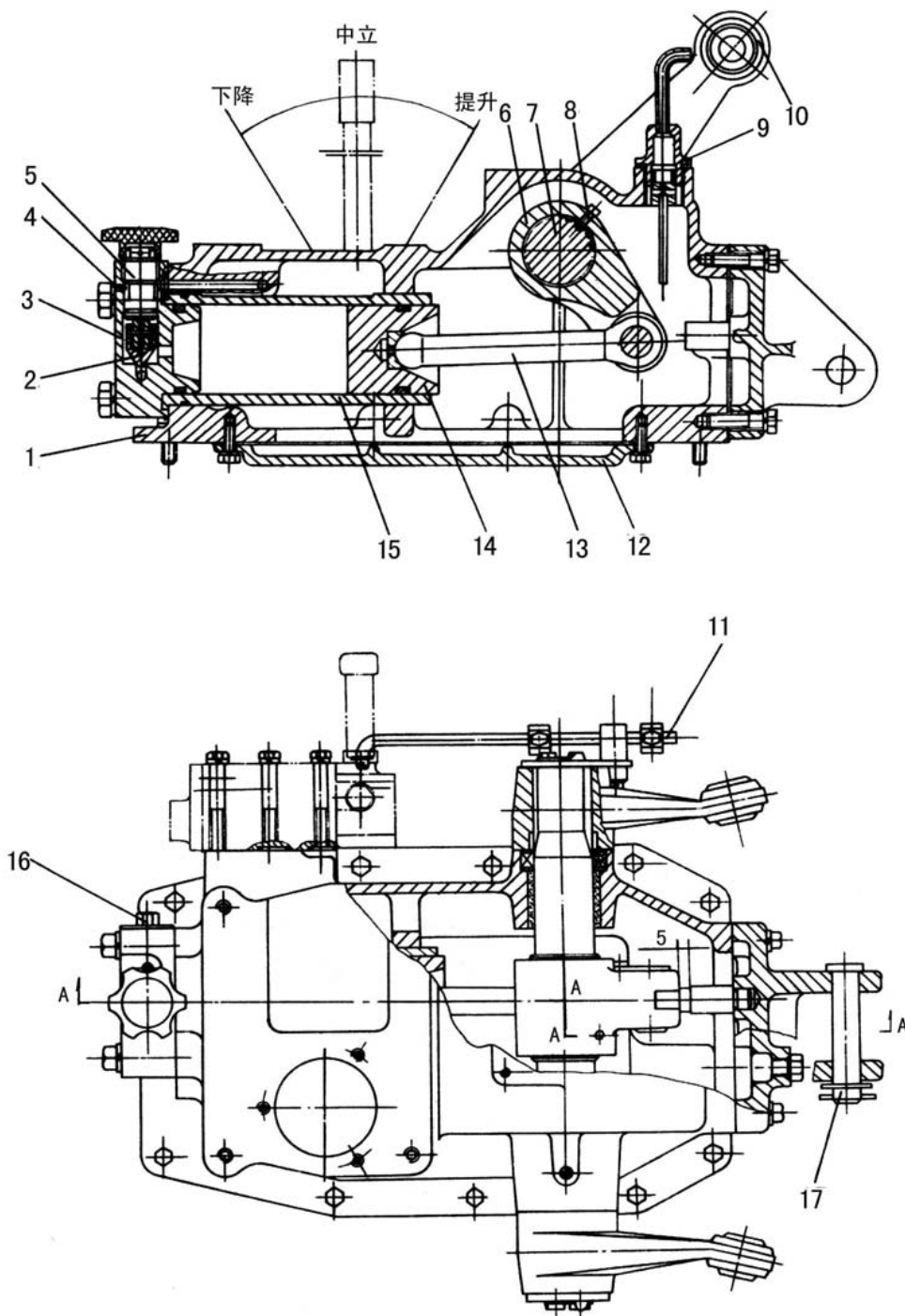

Fig.4-18 Lifter

- 1.Lifter housing 2.Adjusting valve 3.Cylinder head 4.Check screw 5.Bolt of adjusting valve  
 6.Inner lift arm 7.Lift shaft 8.Locating position screw of inner arm 9.Plug and oil dipstick  
 10.Outer lift arm 11.Returning push rod of handle 12.Oil sump 13.Piston rod 14.Piston  
 15.Cylinder 16.Hydraulic output screw plug 17.Front connecting pin of upper pull rod

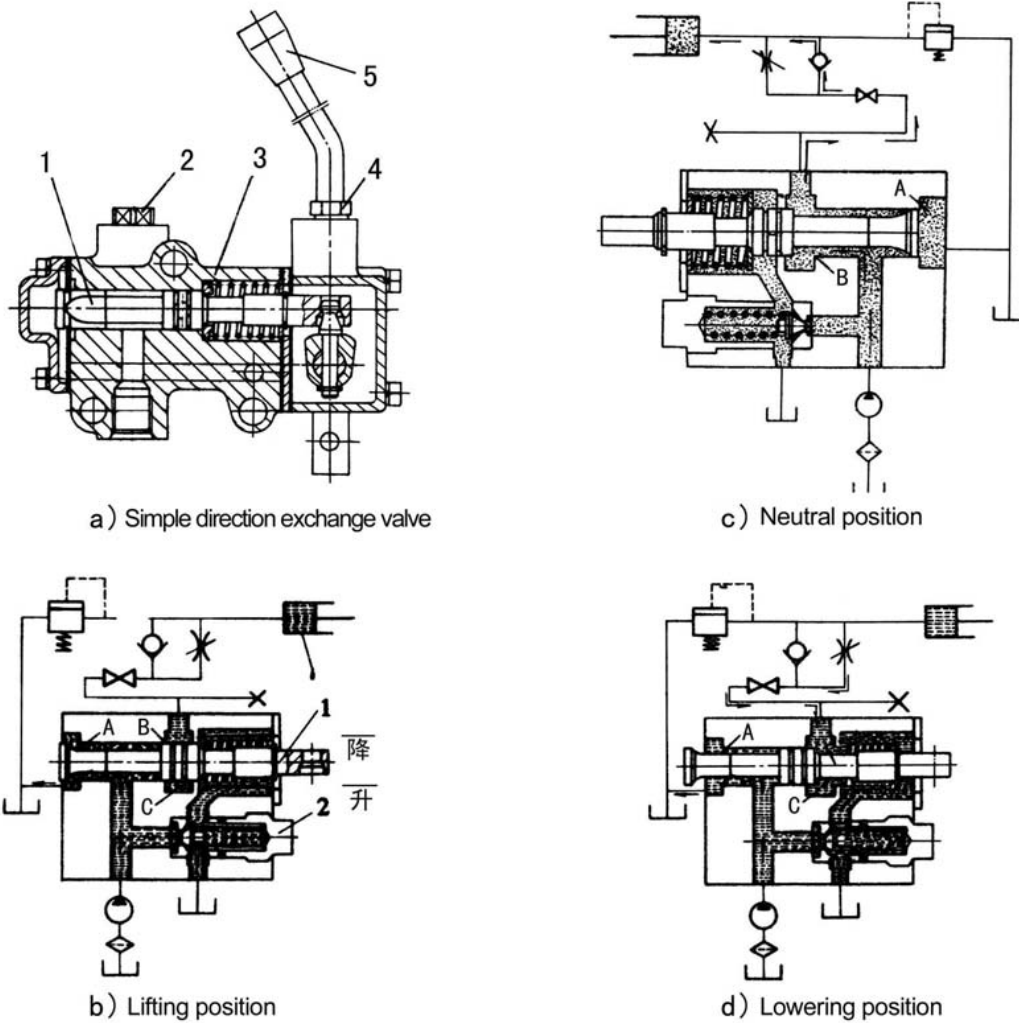

Fig.4-19 Simple direction exchange valve and its working principle  
 1.Main control valve 2.Pressing screw plug of safety valve 3.Valve body 4.Locating mechanism of handle 5.Operation handle 6.Oil cylinder

### B. Working principle of lifter

Fig.4-20 is a working principle diagram of position adjusting of the lifter (with simple direction exchange valve and high adjustable performance). While pulling the operation handle (10) to lowering position, position locating steel ball (8) falls into lowering the position locating slot B on position locating block (7), meanwhile main control valve (5) moves right to the lower position. The oil in the cylinder flows back into oil tank through main control valve (5), and the implement begins to fall down. With the implement falling gradually, stop pin (2) fixed on the stop plate of the lift shaft and the lift shaft together rotate around the lift shaft counterclockwise, and slip along return push rod (4); after they slip to contact the lowering position limiting stop block (3) fixed on the return push rod, they bring the return push rod (4) move right together; at the same time turn the operation handle until position locating steel ball (8) is pushed out of the position locating slot B. In such case, under the action of



tension of return spring (6) of the main control valve, operation handle (10) and main control valve (5) jump back to the neutral position at the same time. And the cylinder stops returning oil, the implement also stops falling. Thus, the falling of the implement depends on the fixed position of lowering return stop block (3) on return push rod (4) i.e. the closer the clearance between lowering return stop block and operation handle is the lower the implement falls. Loosen the tightening bolt of lowering return stop block, the return push rod will lose the ability to make the operation handle return to neutral position. And the main control valve stops at lowering position from beginning to end, while the cylinder is in "floating" state all the time.

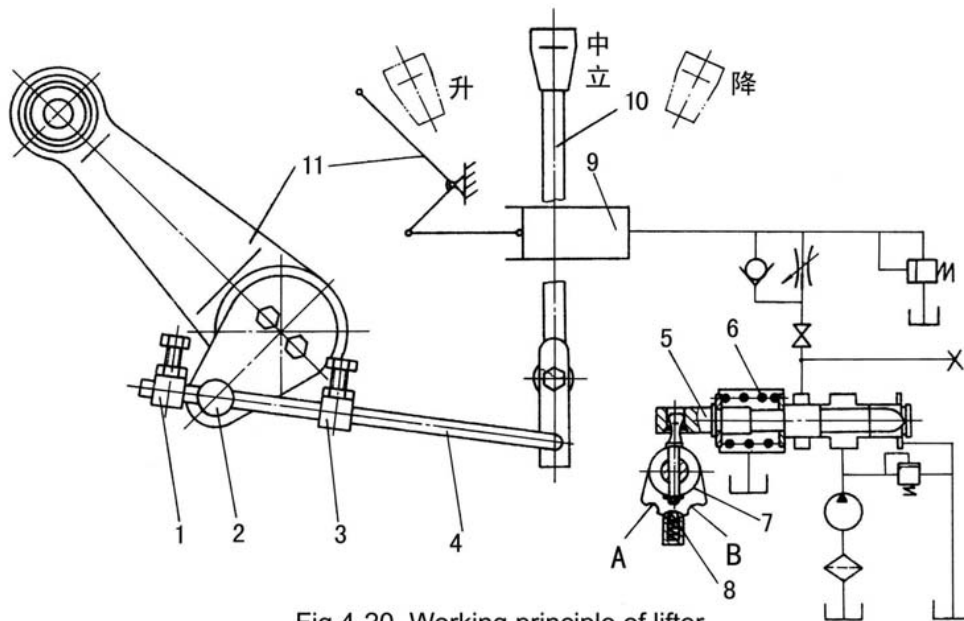

Fig.4-20 Working principle of lifter

- 1.Lifter return stop block 2. Return stop pin 3.Lowering return stop block 4.Return push rod of handle  
5.Main control valve 6.Return spring of sliding valve 7.Position locating block of handle 8.Position locating steel ball 9.Cylinder 10.Operation handle 11.Outer lift arm

While raising the implement, push operation handle (10) to lifting position and then position locating steel ball falls into position locating slot A (Fig.4-20), main control valve (5) moves left to lifting position. The implement begins to rise; with the implement rising gradually, meanwhile, return stop pin (2) rotates around the lift shaft clockwise; when the stop pin slips to contact lifting return stop block (1), drive return push rod (4) to move left, and at the same time rotates operation handle (10) until pull the locating steel ball (8) out of its locating slot. In such case, under the action of the tension of return spring (6), operation handle (10) and main control valve (5) jump to neutral position at the same time. And the oil pump stops supplying oil to the cylinder, the implement stops rising. The raising height of the implement depends on the fixed position of the lift return stop block (1) on the return push

rod (4). The closer the clearance between return stop block (1) and return push rod (4) is, the higher the implement rises.

**Notes:** During operation, if the adjustment is not suitable, it possibly makes the operation handle can not return to its position in time, and can cause parts damage due to overload of hydraulic system.

### C. Adjustment of hydraulic lifter

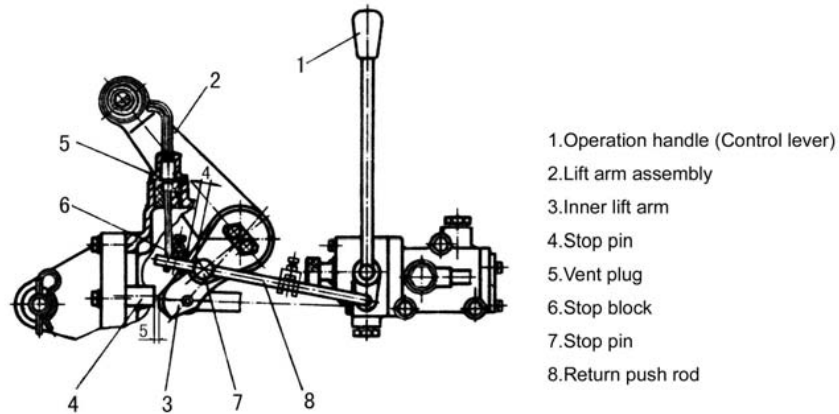

Fig.4-21 Adjustment of lifting position

#### ① Adjustment of the utmost lifting position (Fig.4-21)

Set the control lever (1) at the neutral position which is illustrated in Fig.4-21. Rotate the lift arm assembly (2) upward, until the clearance between the end of inner lift arm (3) and stop pin (4) is not less than 5mm (insert a steel pad through the hole vent plug (5), control this clearance by the pad thickness). Adjust the clearance between stop block (6) and stop pin (7) to be 9-10mm, then fix the stop block on the return push rod (8) with bolt and nut.

#### ② Adjustment of the lowering position

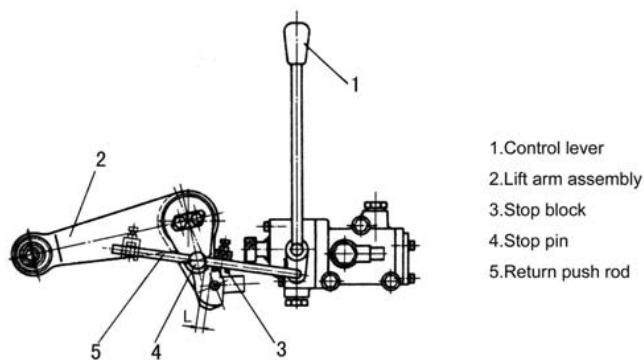

Fig.4-22 Adjustment of lowering position

Set the control lever (1) at the neutral position, rotate the lift arm assembly (2) downwards until the desired lowering position arrives, and adjust the clearance L between stop block (3) and stop pin (4) to be 9-10mm. While in position adjusting, adjustment should be done in

ploughing and forwarding; as the plough lowers into the soil and the required ploughing

depth is reached, adjust the clearance between lowering stop block (3) and stop pin (4). After adjustment, fix stop block (3) on return push rod (5) with bolt and nut, then raise the implement several times to check the adjustment.

If the implement is provided with a supporting wheel, the floating control needs to be used. Meanwhile, adjust lowering stop block (3) to the position where control lever (1) of distributor (valve) will not return to neutral position.

### ③ Adjustment of lowering speed

During adjustment, the lowering speed of the implement can be adjusted through rotating the adjusting valve bolt (5) (see Fig.4-18). When the lowering speed is suitably adjusted, use check screw (4) to limit the moving range of adjusting valve bolt.

### ④ Adjustment of safety valve

Safety valve has been adjusted before leaving the factory. In general, dismantling in operation is not permitted anyhow. If the readjustment is necessary, it should be done on special pressure test stand. The oil for test is HC-8(SY1152-77), the oil temperature should be controlled as  $65 \pm 5 \text{ }^{\circ}\text{C}$ . When the press screw plug of safety valve is rotated clockwise, the higher opening pressure is got, or vice versa.

In hydraulic system, as the precision of many parts is high, and the assembly parts have been carefully tested and adjusted, cleanliness of the hydraulic oil, cleaning oil and the environment should be especially paid attention to during operation, maintenance and fixing the breakdowns. Generally free dismount is not allowed.

Notes: Before starting the engine, make sure there is enough oil in the lifter housing, so as to avoid damage to the hydraulic gear pump.

## 10. Use and adjustment of air brake device of trailer

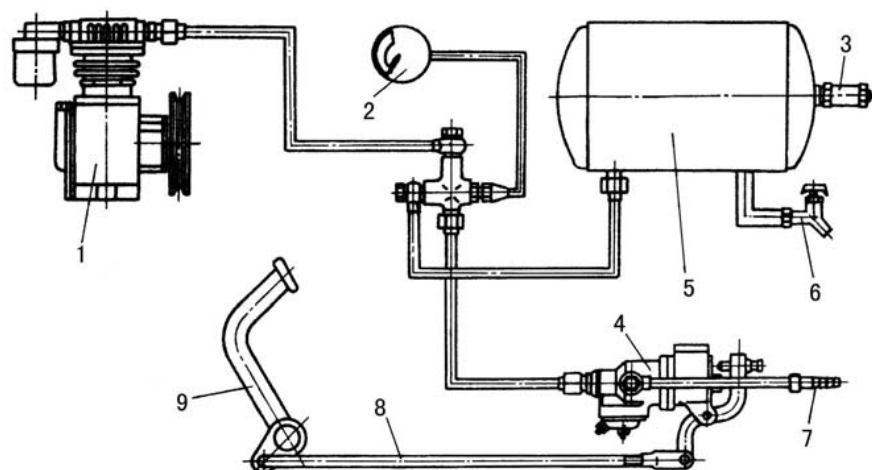

Fig.4-23 Trailer air brake system diagram

1.Air compressor 2.Air pressure gauge 3.Safety valve 4.Brake valve 5.Receiver  
6.Air(Water)-bleed valve 7.Air-bleed pipe of brake valve 8.Connecting rod 9.Brake pedal

In order to ensure safety of the trailer transportation of the tractor and achieve the aim of prompt stop of the tractor and trailer, air brake system is mounted on the tractor. The system is made up of air compressor (1), receiver (5), brake valve (4), air pressure gauge and pipes (Fig.4-23).

### 1) Working process of air brake device of trailer

Air brake trailer is braked through the compressed air driving the brake hung on the trailer wheels. Firstly the compressed air is conveyed to receiver from air compressor through pipes, then is conveyed to the brake air chamber of the trailer wheels through air-bleed hole (hole B in Fig.4-24) of the brake valve. When stepping on the brake pedal, through the connecting rod (8 in Fig.4-23) driving the pull arm 10 of brake valve (Fig.4-24) to rotate around axle pin 13 to make adjusting bolt 12 press down brake pull rod 9, compress balance spring 7, push core rod 5, compress return spring 4, push valve seat assembly 3 aside (compress valve seat spring 2), open high pressure air passage, and at this moment, the compressed air of receiver, from hole A to valve seat hole, then to mouth of hole B and continuously respectively enter the left and right brake air chambers of trailer wheels through air-bleed pipe (7 in Fig.4-23) of brake valve and three-way pipe connector and push the brake tappets of left and right brakes, and thus achieve brake of the trailer.

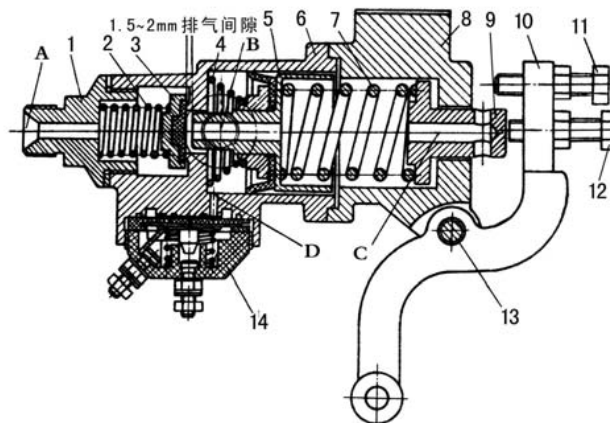

Fig.4-24 Brake valve

- 1.Valve cover connector 2.Valve seat spring 3.Valve seat assembly
- 4.Return spring 5.Core rod assembly 6.Left housing 7.Balance spring
- 8.Right housing 9.Brake tappet 10.Pull arm 11.Limiting bolt
- 12.Adjusting bolt 13.Axle pin 14.Air-moved switch of brake light

After completing brake, loosen foot brake pedal, the brake adjusting bolt will return to the initial position, and the brake tappets and core rod assembly will also return to their initial position under the effort of compressed return spring; then the valve seat assembly 3 will move right to contact the valve mouth on left housing 6 under the effort of compressed

valve seat spring, and reseal the passage between receiver and the left and right brake air chamber of the trailer. At this moment the waste gas (compressed air) in left and right air chamber will go into the air through pipes, hole B of brake valve, inner hole of core rod and inner hole C of tappets.(Fig.4-24).

## **2) Use and adjustment of air brake device of trailer**

① During working of air compressor, if the air pressure is too low, seal performance of exhaust valve should be checked, and cleaned or ground if necessary. If the air compressor has worked for 24 hours, and the oil gathered in the receiver is more than 15-20ml, the wear condition of the piston rings of air compressor should be checked, and it should be replaced if necessary. The air compressor should be checked or be filled with oil after every ten hours' work.

### **② Use and maintenance of brake valve**

During using if the air pressure of receiver drops too fast, and all the pipe connectors are confirmed to have no air leak, then screw out the valve cover connector 1 (Fig.4-24), clean the gathered dust on the surface of the rubber of valve seat assembly 3, and slightly grind the compressed prints on fine abrasive cloth if necessary. Generally after 1000 hours' work of the valve, should dismantle and clean all the parts, grind the valve seat, adjust the maximum pressure of brake, and check the seal performance after assembling.

### **③ Adjustment of brake pressure**

When the brake pedals are stepped into the lowest place, the maximum pressure of the air entered into the brake air chambers of trailer should be 0.45-0.5MPa. During adjustment, connect an air pressure gauge in the pipes which pass through brake air chamber, rotate the adjusting bolt 12 to contact tappet 9 according to Fig.4-24, then step on the pedals again to the lowest position, if the numerical value on the air pressure gauge is lower than 0.45Mpa, then use nut to lock the limiting bolt tightly.

### **④ Adjustment of brake time**

The brake time of trailer should be basically synchronous with the brake time of the tractor, otherwise it should be readjusted; adjust connecting rod 8 (Fig.4-23) to add its length, the brake time of trailer will advance; adjust connecting rod 8 and reduce its length, the brake time of trailer will extend. Generally the brake time of air brake trailer should be a bit shorter than the brake time of tractor.

## V . Main Troubles of Tractors and Trouble Shooting

### 1. Engine

#### 1) Adjustment of dual stage clutch

Cause	Remedies
1.Weather cold	Pour hot water into the radiator or preheat the oil before pouring it into crankcase
2.Fuel flow unsteady	Check and clean the fuel pipe line and filter element
3.Air leaking into the fuel pipe line	Remove the air and tighten all fuel pipe connections
4.Pump plunger and barrel , delivery valve and its seat ,nozzle and its body sticking or damaged	Repair or replace them
5.Loss of compression pressure, because of the inlet or exhaust valve leaky ,no valve clearance , cylinder head gasket damaged , piston rings gummed up or worn nut	Lap inlet or exhaust valve . Adjust the valve clearance .Renew cyliner head gasket or piston rings, if necessary.
6.Shortage of the battery electricity	Recharge or replace the battery

#### 2) Engine does not develop full power

Cause	Remedies
1.Air filter or fuel filter choked	Clean it in light fuel or kerosene
2.Beginning of fuel delivery incorrect	Adjust according to the recommended procedure
3.The fuel containing water	Drain out the water deposit and change fuel
4.Nozzle needle sticking or holes choked	Repair or replace the nozzle unit
5.Inlet or exhaust valve leaking , or valve clearance incorrect	Lap valve or adjust valve clearance
6.Main bearing or con-rod bearing worn badly or seized up	Repair or replace them
7.Poor uniformity of single cylinder output	Calibrate the fuel delivery of injection pump and the injection pressure of injector

### 3) Engine does not develop full power

Check if the engine can be cranked by hand . If not , the cause may be as follows.

#### A.Crankshaft and bearing seized up Repair or change them

Cause	Remedies
1.Oil not enough or broken off	Check if oil gallery is stopped up and if the oil in crankcase is enough
2.Oil diluted or aged	Check if the oil has been diluted by the leakage fuel from fuel pump plunger unit and if the oil is aged. If so ,settle the problem
3.Sudden oil pump failure or oil filter stopped up or relief valve/by-pass valve went wrong	Repair or change oil pump ,Clean or change the element

#### B.Piston sticking Repair or change piston cylinder liner

Cause	Remedies
1.Engine overheated due to lack of cooling water	Check regularly if the cooling water is enough
2.Cylinder overheated because of water scale	Scour out the water jacket
3.Engine overloaded	Follow the regulations of operation specified
4.Low tension of V-belt	Adjust the tension or change the belt

If the engine can be cranked freely , the causes may be as follows.

Cause	Remedies
1.Fuel consumed or fuel pipe crack	Replace fuel or change the pipe
2.Fuel containing air	Remove the air
3.Fuel filter or fuel pipe line blocked up	Rinse the filter or the pipe
4.Plunger spring inside the injection pump broken	Replace the spring with a new one

#### 4) Engine smoking abnormal

Cause	Remedies
1.Engine overloaded	Lighten the load . If the matching of engine and driven unit is inadequate ,correct it .
2.Black smoking because of second compression ring fitted inversely or oil scraper ring worn out badly	Refit the ring or change the oil scraper ring.
3.While smoke because of fuel containing water , bad atomization of fuel and low injection pressure	Ringse fuel tank and filter with filtered fuel. Repair the nozzle assembly . Calibrate the pressure

#### 5) Engine overheat

Cause	Remedies
1.Low tension of v-belt	Adjust the tension or change the v-belt
2.Engine overheated	Lighten the load
3.High exhaust temperature because of fuel delivery delayed or leakage of fuel from injector	Repair the fuel delivery system

## 2. Transmission system

### 1) Clutch slippage

Cause	Remedies
1.Friction disc surfaces stained with oil	Clean the surface with diesel , and eliminate leakage points
2.Clutch pressing springs weakened or broken	Replace the spring
3.Too short free travel or no free travel of pedal , unidentical clearance between release bearing and release levers	Readjust pedal free travel according to requirements
4. Friction disc worn out or broken	Replace friction disc



## 2) Incomplete disengagement of clutch and difficult shifting

Cause	Remedies
1.Excessive or too small free travel	Readjust according to requirements
2.Unidentical clearance between 3 release levers and release bearing	Readjust according to requirements

## 3) Abnormal noise in gearbox

Cause	Remedies
1.Excessive wear or cracking of the gear teeth faces	Replace gears
2.Gear teeth breakage	Replace gear
3.Bearing worn out excessively or damaged	Replace bearings
4.Improper meshing backlash of main drive gears	Readjust it to required numerical value

## 4) Gearbox overheat (oil temperature is more than 90 °C )

Cause	Remedies
1.Too small bearing clearance or meshing clearance of bevel gears	Readjust to required numerical value
2.Lack of oil	Fill lubrication oil to required level
3.Poor quality of oil	Clean with diesel ,add required lubricating oil

## 3. Transmission system

### 1) Ineffective brake

Cause	Remedies
1.Friction linings worn out excessively	Replace friction linings
2.Brake linings stained with oil	Clean brake linings with gasoline and remove oil leakage point
3.Adjust improperly	Readjust according to requirements

## 2) Riding direction change with braking on both sides of driving wheel

Cause	Remedies
1.Right and left brake pedal travel different	Readjust brake pedal travel
2.One side of brake linings stained oil	Flush the stained linings with gasoline and remove
3.Wear on right and left friction linings unidentical	Adjust or replace friction linings

## 3) Incomplete disengagement and generating heat

Cause	Remedies
1.Return spring of brake shoes weakened	Replace spring
2.Too small clearance between brake linings and drum	Adjust pedal free travel

## 4. Steering gear and walking system

### 1) Difficult steering

Cause	Remedies
1.Excessive clearance between crankpin and worm or steering screw worm and nut	Readjust the clearance or replace the worn parts
2.Low inflation pressure in front tires	Inflate as specified
3. Insufficient oil supply of oil pump	Choose suitable oil pump or check the oil pump
4. Air in steering system	Remove air and check suck oil pipe
5. Fuel tank is not full	Fill to required level

### 2) Difficult steering

Cause	Remedies
1. Inflation pressure of right and left tyres not identical	Inflate as specified
2. Wear of the treads on left and right tyres not identical	Replace with new tyres

### 3) Oscillation of the front wheels

Cause	Remedies
1. Excessive clearance of tapered roller bearing on front wheel or bearing worn out	Readjust clearance or replace the bearing
2. Ball pins or joint seat worn out	Replace ball joint or ball joint seat
3. Pendulum shaft bush worn out	Replace bush
4. Steering knuckle shaft bush worn out	Replace shaft bush

### 4) Early worn out of front wheel tyres

Cause	Remedies
1. Improper adjustment of front toe-in	Readjust toe-in
2. Low inflation pressure of tyre	Inflate tyre to specified pressure
3. Driving wheel mounted reversely	Remount the driving wheel

## 5. Hydraulic hitch system

### 1) Implements not being able to lower or lift

Cause	Remedies
Adjusting valve locked	Loosen adjusting valve

### 2) Fast still falling of implements

Cause	Remedies
1. Cylinder and piston worn out	Check and repair or replace cylinder and piston
2. Upper oil seal of piston damaged	Replace oil seal
3. Sliding valve of divider worn out	Replace divider

## 6. Trailer air brake system

### 1) Insufficient air pressure

Cause	Remedies
1. Air pump belt is too loose	Adjust tightness of belt or replace belt
2. Pipe connectors leak	Check out the leaking position and remove breakdowns
3. Inlet and outlet valve of air compressor not sealed and spring damaged	Grind valve seat, replace spring
4. Piston rings and cylinder lining of air compressor seriously damaged	Replace piston rings and cylinder lining
5. Filter blocked	Clean filter
6. Safety valve is not completely closed or is not flexible	Check and repair or replace safety valve
7. Cylinder head studs of air compressor is loose or cylinder gasket leaks	Tightly screw cylinder head studs or replace cylinder gasket

2) Insufficient brake force, air pressure gauge pointer continuously falls during brake, continuous exhaust sounds at exhaust mouth

Cause	Remedies
1. Impurity between brake valve core rod end face and valve	Clean valve seat, remove impurity
2. Valve seat ground or damaged	Repair or replace valve seat

### 3) Brake situation not being able to be relieved after loosening brake pedal

Cause	Remedies
1. Exhaust clearance too small or no clearance	Adjusting bolt wound out to increase clearance, exhaust clearance should be among 1.5-2mm
2. Balance spring not suitably mounted	Remount balance spring

## 7. Electrical system

### 1) Starter

Cause	Remedies
<b>1. Starter is out of running</b>	
(1) Connecting wire broken or poor contact of connecting wire	Weld or tighten the nuts on contacts
(2) Low voltage of battery	Recharge or replace battery
(3) Poor contact of brush and commutator	Clean surface of commutator or replace brush
(4) Inner short or broken circuit of starter	Repair after checking
<b>2. Starter can run idle, but fails to start engine</b>	
(1) Poor contact of brush and commutator	Clean commutator contact face
(2) Surface of commutator burned out or stained with oil dust	Repair it well with abrasive cloth or clean oil dust out
(3) Poor contact of connectors	Clean or tightly screw contact point
(4) Poor contact of solenoid switch	Check and repair solenoid switch
(5) Battery insufficient or voltage too low	(5) Recharge battery after checking
<b>3. Starter runs with starting pinion unmeshed and pinions knocked at each other. Too small travel of armature</b>	Screw the connecting screw of armature in for 2-3 rings

### 2) Generator

Cause	Remedies
<b>1. Generator fails to generate current</b>	
(1) Connecting wires loose, broken, short circuit or wrongly connected	Repair well after checking
(2) Diode damaged, wires broken or have short circuit	Replace it or repair it
(3) Winding of rotor or stator broken, have short circuit or earthing	Repair or replace
(4) Regulated voltage of regulator too low	Adjust the voltage a bit higher
(5) Regulator terminal burnt out or inside wiring connector broken	Check and repair
<b>2. Insufficient output power of generator</b>	
(1) Coils of stator and rotor part short circuit or broken	Repair or replace

<b>Cause</b>	<b>Remedies</b>
(2) Each or both of the diode damaged	Replace
(3) Generator belt too loose	Adjust to tighten belt
<b>3. Unsteady current</b>	
(1) Generator belt slips	Remove oil dust or adjust belt tension
(2) Poor contact of recharged circuit	Check and remove
(3) Coil of stator and rotor will be in short circuit or broken circuit	Repair or replace
(4) Breakdowns of regulator	Repair or replace
<b>4. Abnormal noise of generator</b>	
(1) Improper mount of generator, interference between rotating part and fixing part	Find out interference, adjust mounting position
(2) Bearing damaged	Replace bearing
(3) Rotor knocking against stator	Repair
<b>5. Burnt smell of generator</b>	
(1) Damaged diode cause one phase or two phases burnt	Replace
(2) Stator knocking against rotor core and burned and cause short circuit of winding of stator and rotor coil	Repair or replace coil
(3) Ineffective regulator or too high of regulated voltage, overloaded for a long time	Replace or adjust
<b>6. Charged current too big</b>	
(1) Inner short circuit of single grille of battery	Replace
(2) Too high regulated voltage of regulator	Adjust lower
(3) Poor earthing of regulator	Check and repair
(4) Regulator terminal ineffective and dirty	Repair and clean

### 3) Battery

Cause	Remedies
<b>1. Frequently insufficient electric power</b>	
(1) Breakdowns of generator or regulator or no charging electric current	<b>Repair generator or regulator</b>
(2) Loosened connecting wires of charging circuit or rust making resistance increase	<b>(2) Check to see whether terminals and bolts of connecting wires are loose or not and tighten them, or remove rust</b>
(3) Short circuit of plate	<b>(3) Check and repair</b>
<b>2. Automatically discharging of battery, too high impurity content of plate material or impure electrolyte</b>	<b>2. Completely discharge battery or overdischarge battery to make plate impurity enter electrolyte then pour electrolyte out and clean with distilled water, and refill with new electrolyte and recharge</b>
<b>3. Charge capacity of battery distinctively reduces (low discharging voltage, high charging voltage, low indensity of electrolyte and plates sulphurized)</b>	
(1) Frequently insufficient electric power	<b>(1) Charge for a long time with small electric current or completely charge and completely discharge repeatedly</b>
(2) Discharge in small electric current for a long time and not charging in time	<b>(2) Make activated material restore. Or charge with sulphre removal method</b>
(3) Too low of electrolyte lever, upper part of plate emerging from electrolyte lever	<b>(3) Replenish electrolyte</b>

## Chapter VI Appendix

### 1. Wiring diagram of the electrical system

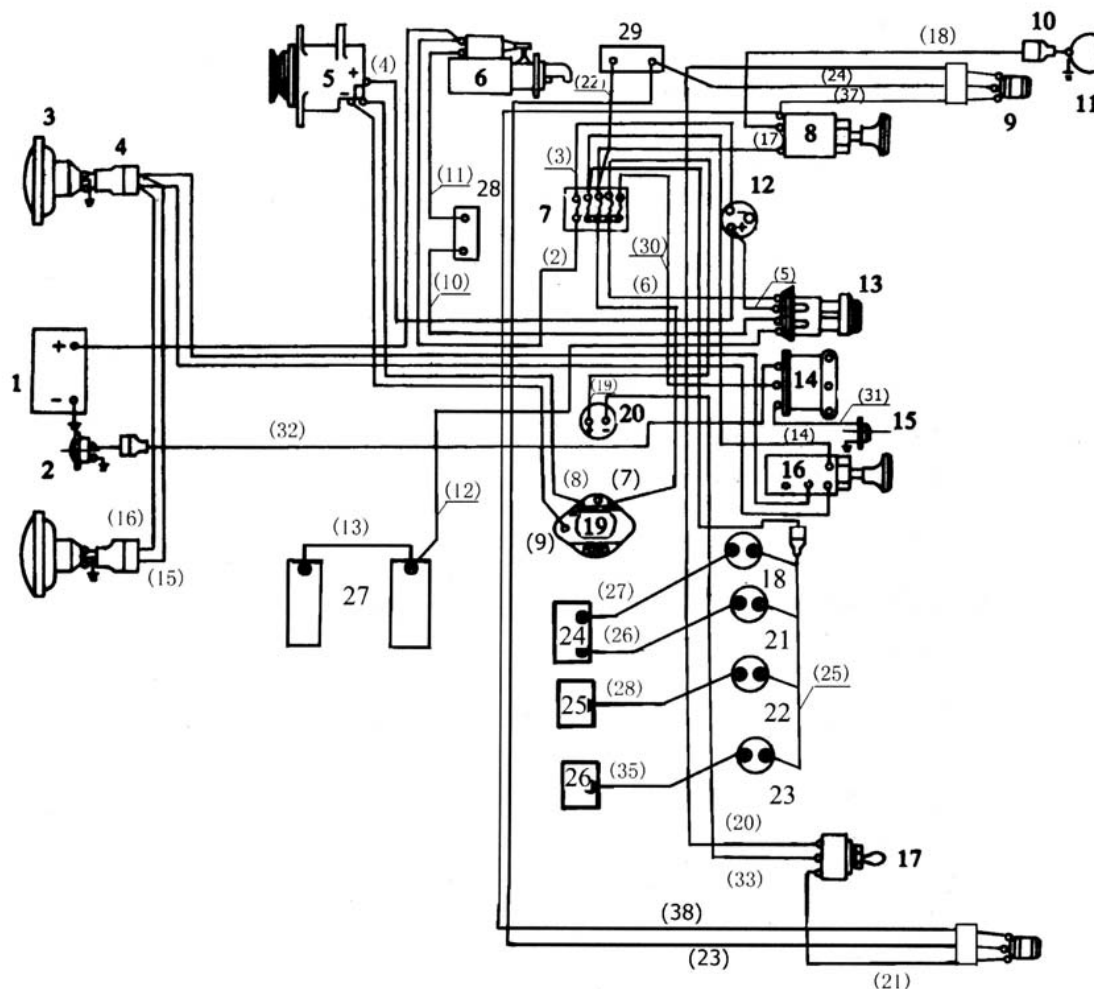

Fig.6-1 Wiring diagram of the electrical system

- 1.Battery 6-Q(A)-80
- 2.Electrical horn DL38-12
- 3.Front head lamp
- 4.Double plug socket
- 5.Silicon rectifying alternator
- 6.Starter
- 7.Fuse box BX 505
- 8.One-position switch
- 9.Turning signal light
- 10.One plug socket
- 11.Rear work light
- 12.Ammeter 307A
- 13.Starting switch JK424/JK290
- 14.Horn relay
- 15.Horn button
- 16.Two-position switch
- 17.Direction indicating light switch
- 18.Oil pressure gauge
- 19.Regulator
- 20.Thermal flasher
- 21.Counting timer
- 22.Water temperature gauge
- 23.Fuel gauge
- 24.Oil pressure plug
- 25.Water temperature gauge
- 26.Fuel sensor
- 27.Preheater
- 28.Switch
- 29.Brake switch

### 2. Accessories for customers to order

Customers may order and purchase the following accessories of the tractors from our factory according to requirements:



<b>Serial No.</b>	<b>Name</b>	<b>Quantity</b>	<b>Purpose</b>
<b>1</b>	<b>High-lugged tyres</b>	<b>One pair</b>	<b>Used in paddy field</b>
<b>2</b>	<b>Turf tyres</b>	<b>Two pairs</b>	<b>For garden use</b>
<b>3</b>	<b>Cab</b>	<b>1</b>	<b>Improve driver's working condition</b>
<b>4</b>	<b>Protective roll bar</b>	<b>1</b>	<b>Ensure safety of drivers</b>
<b>5</b>	<b>Belt pulley</b>	<b>1</b>	<b>For fixed operation</b>

### 3. Distribution diagram of rolling bearing and transmission system of Jm series tractors

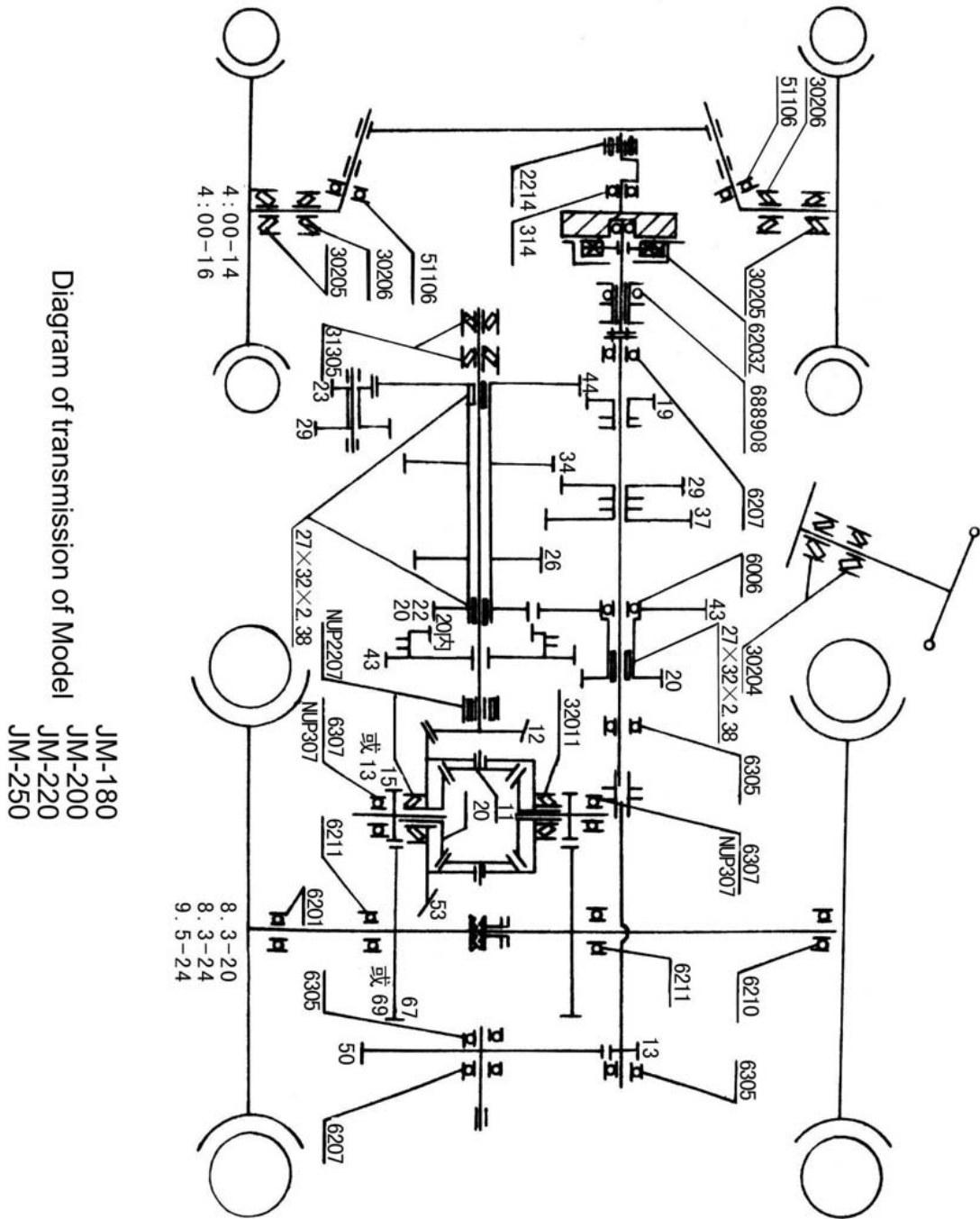

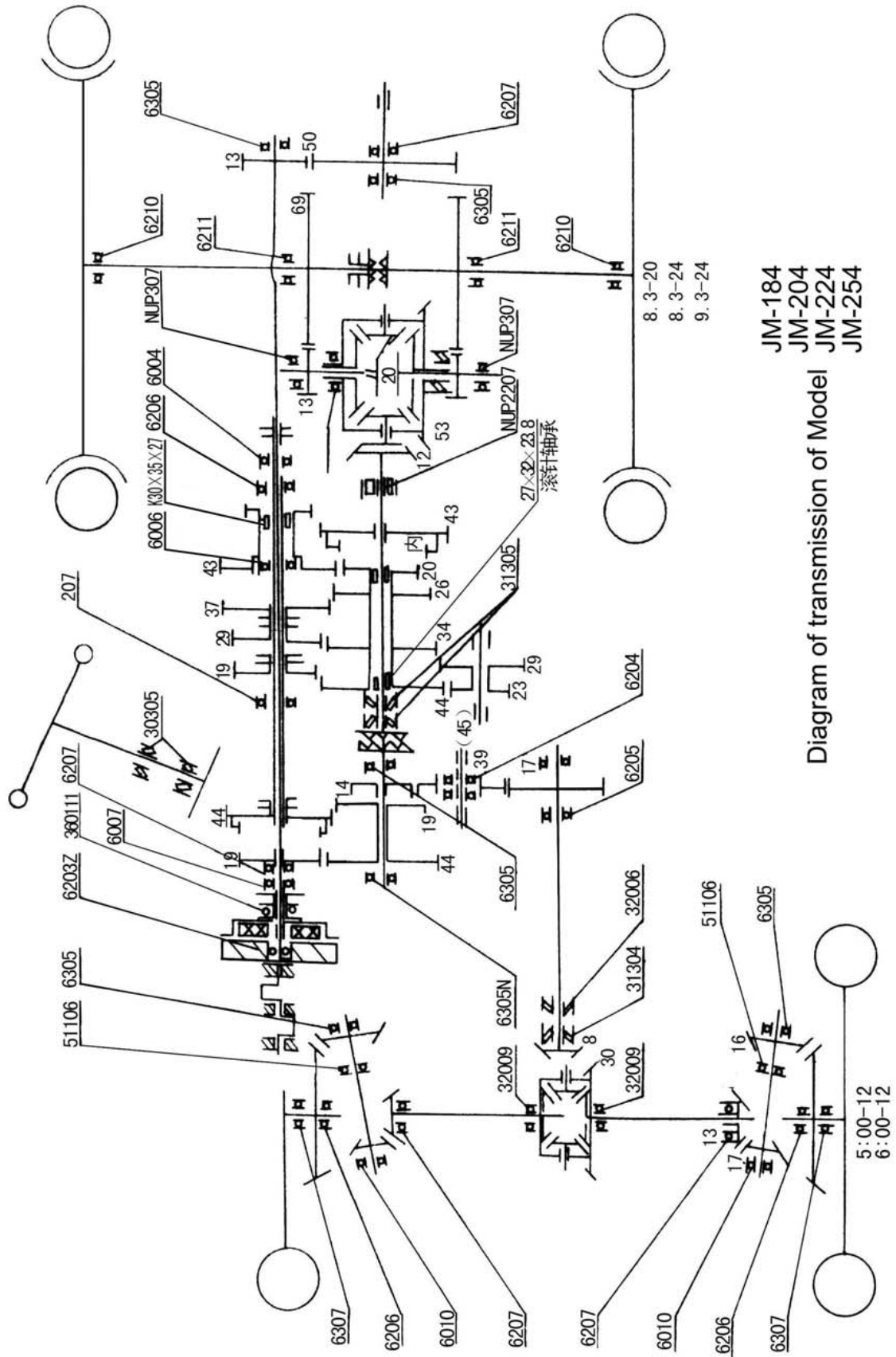

JM-184  
 JM-204  
 JM-224  
 JM-254

Diagram of transmission of Model

#### 4. Specifications and distributions of oil seals in JM series tractors' chassis

Parts	Specifications	positions	Qty.	
Transmission box	JB2600-80 Oil seal	PD35 × 55 × 8	Front end of 1st shaft	1
		SD35 × 55 × 10	Inside bearing cover of PTO shaft	1
PD50 × 72 × 12		Outer of driving shaft bushing	4	
PD50 × 80 × 12		Outer of bearing seat of final transmission shaft	4	
PD55 × 75 × 12		Inner side of driving shaft bushing	2	
GB3452.1-82 O-ring		11.8 × 1.8	PTO shifting fork shaft	1
	15 × 2.65	Sub-transmission shifting lever	2	
	15 × 2.65	Shifting fork shaft of differential lock	1	
	22.4 × 2.65	Outer of reverse shaft	1	
	28 × 3.55	Driving gear shaft of final transmission	2	
	67 × 3.55	Front bearing seat of 2nd shaft	1	
	103 × 3.55	Out ring of bearing seat	2	
	112 × 3.55	Inner of driving shaft bushing	2	
Creeper	GB3452.1-82 O-ring	9.5 × 2.65	Creeper shifting fork shaft	1
		10 × 2.65	Power shifting fork shaft of transfer box	1
		11.2 × 2.65	Creeper shifting lever	2
Transfer box	JB2600-80 Oil seal GB9877.1	SG25 × 40 × 8	Oil seal seat of transfer box	2
		FB25 × 47 × 7	Oil seal seat of Agracat-254 transfer box	1
	GB3452.1-82 O-ring	15 × 2.65	Idle shaft	1
		58 × 3.55	Oil seal seat of transfer box	1
		54.5 × 3.55	Front fixing seat	1
Dual stage clutch	JB2600-80 Oil seal GB3452.1-82 O-ring	SD35 × 55 × 12	Support frame of release bearing seat	1
		19 × 2.65	Main clutch shaft	2
Brake	GB3452.1-82 O-ring	15 × 2.65	Brake camshaft	2

Parts	Specifications		positions	Qty.
Front axle	Non-standard oil seal of standing shaft	40 × 48 × 6.5	Lower part of steering knuckle of front axle	2
	Non-standard oil seal of standing shaft	38 × 62 × 11.5	Inner end of front wheel hub	2
	GB3452.1-82 O-ring	30 × 3.55	Upper part of left end right steering knuckle Two ends of pendulum shaft	2 2
Front drive axle	JB2600-80 Oil seal	SD35 × 56 × 12	Bearing seat of driving bevel gear	2
		W50 × 72 × 7	Left, right side reduction housing	2
		W50 × 72 × 7	Driving shaft	2
		W50 × 72 × 12	Left, right side reduction housing	2
	GB3452.1-82 O-ring	W50 × 72 × 12	Driving shaft	2
		21.2 × 3.55	Driving bevel gear	1
		28 × 3.55	Inner of front pendulum shaft	1
		34.5 × 3.55	Upper bearing cover	2
GB3452.1-82 O-ring	63 × 3.55	Middle of front pendulum shaft	1	
	69 × 3.55	Back support seat assy	1	
	77.5 × 3.55	Inner of bearing seat of driving bevel gear	1	
	82.5 × 3.55	Middle of bearing seat of driving bevel gear	1	
Steering gear	JB2600-80 Oil seal	PD30 × 45 × 8	Outer of steering rock arm shaft	1
	GB3452.1-82 O-ring	11.8 × 2.65	Adjusting bolt	1
Fuel tank	GB3452.1-82 O-ring	31.5 × 3.55	outside of fuel delivery flange	1

Parts	Specifications		positions	Qty.
Lifter	JB2600-80 Oil seal	SG42 × 62 × 10	Outside of lift shaft	2
	GB3452.1-82 O-ring	9 × 1.8	Inside of oil drain plug	1
		13.2 × 2.65	Joint of distributor and lifter	2
		13.2 × 2.65	Outside of pressing screw plug of lifter	1
		17 × 2.65	Adjusting valve spool rod	1
19 × 2.65	Joint of distributor and lifter	1		
GB3452.1-82 O-ring	63 × 5.7	Outside of piston	1	
	63 × 5.7	Inside of cylinder head	1	
GB3452.1-82 O-ring	9 × 2.65	Safety valve seat	1	
	9 × 2.65	Inside of distributor handle shaft	1	
	15 × 2.65	Lower of pressing screw plug of distributor	1	

### 5. Sizes of hitch system

Model Parameter	JM200	JM204	JM250,	JM254
H	690	705	702	702
H <sub>1</sub>	200	146	180	180
h	470	470	495	495
R	497.5	497.5	525	525
R <sub>1</sub>	545	600	625	625
R <sub>2</sub> *	478	533	558	558
R <sub>3</sub>	250	268.5	280	280
R <sub>4</sub> *	446	453	475	475
R <sub>5</sub>	130	190	196	196
B	520	546	718	718
δ	16 °	13.5 °	10.5 °	10.5 °

Note:\* are adjustable sizes

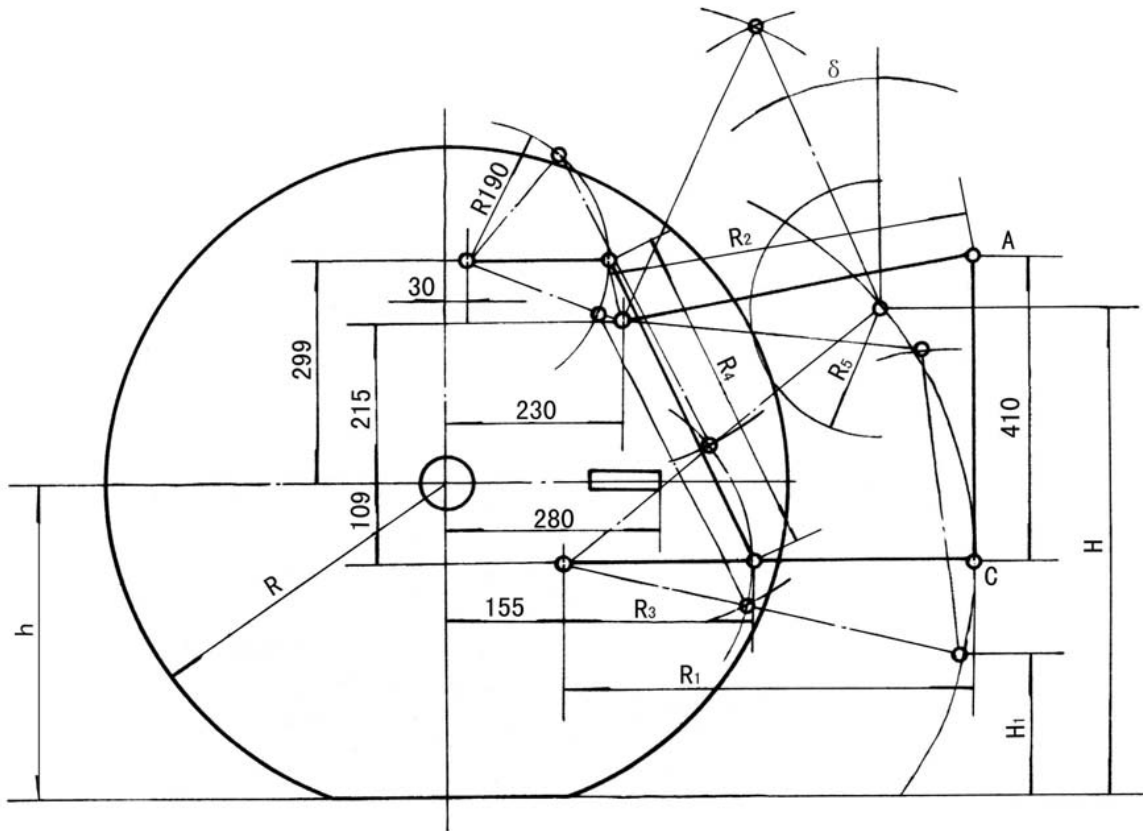

A点连接尺寸

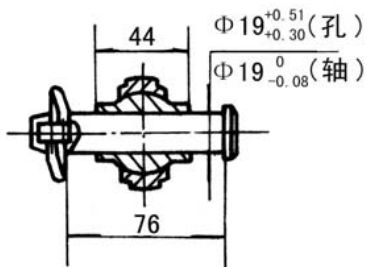

C点连接尺寸

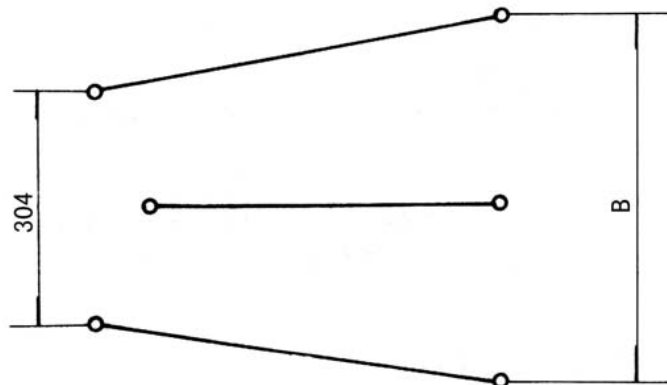
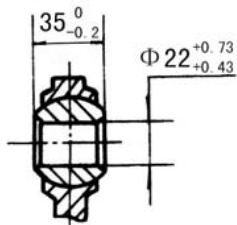

## 6. OECD approval No. of JM series tractors

<b>Model</b>	<b>JM-180</b>	<b>JM-200</b>	<b>JM-204</b>	<b>JM-254</b>				
<b>OECD Approval No. (Full code)</b>	<b>1354</b>	<b>1563</b>	<b>1657</b>	<b>1650</b>				

### OECD approval No. of tractors to which the protective structure are fitted

Model	OECD approval number
<b>JM-180</b>	<b>NT/ROPS - R/S0110/4</b>
<b>JM-184</b>	<b>NT/ROPS - R/S0110/3</b>
<b>JM-200</b>	<b>NT/ROPS - R/S0110/2</b>
<b>JM-204</b>	<b>NT/ROPS - R/S0110/1</b>



**MAHINDRA YUEDA (YANCHENG) TRACTOR CO.,LTD.**

**Add. : 90# South Wengang Road Yancheng City, Jiangsu Province**

**Tel: 0086-515-88231130/88231131**

**Fax: 0086-515-88229791**

**Postcode: 224002**

**Ttp: //www.jm-tractor.com**

**E-mail: tractorobd@yantuo.cn**